

Plan Check Construction Guidelines

FOR NEW AND REMODELED RETAIL FOOD FACILITIES

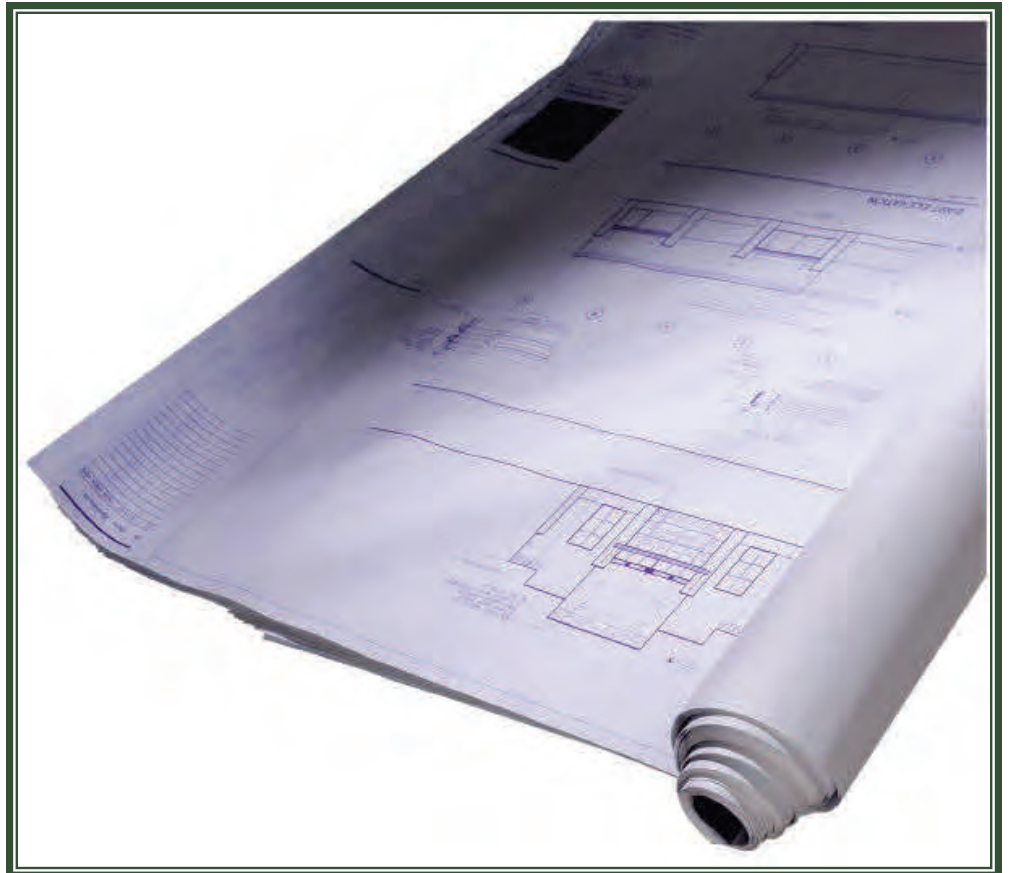

**Merced County
Department of Public
Health
Division of Environmental
Health**

260 E 15th Street
Merced, CA 95341

Phone: 209-381-1100
Fax: 209-384-1593
<http://www.countyofmerced.com/eh>

Table of Contents

SECTION 1.....	The Plan Check Process	
Introduction		1
Plans and Fees		1
Plan Submittal.....		2
Processing Plans		5
Construction Inspections.....		5
SECTION 2		
Summary of the Plan Check Process		
Steps 1 through 5.....		6
SECTION 3.....	Construction and Equipment Requirements	
Floors		8
Walls and Ceilings		11
Conduit and Piping.....		12
SECTION 4		
Equipment – General Requirements		14
Mechanical Ventilation for Cooking Equipment		16
Refrigeration and Freezer Units.....		22
Ice Machines.....		23
Customer Self-Serve Equipment		23
SECTION 5		
Sinks		28
Dishwashing Machines		30
Indirect Waste Drainage		32
Waste Disposal		35
Water Supply and Sewage Disposal		35
SECTION 6		
Janitorial Facilities.....		36
Backflow Prevention		36
Hot Water Supply.....		37
SECTION 7		
Doors		38
Windows		38
Lighting		39
Signs		39

SECTION 8

Shelving40
Storage40
Restrooms.....41
Employee Change/Storage Rooms42

SECTION 9.....Miscellaneous

Enclosed Facility43
Vermin Exclusion43
Areas of Multiple Uses43
Grease Traps and Grease Interceptors43

SECTION 10.....Forms

Room Finish Schedule
Hood Worksheet
Hot Water Demand Worksheet
Hourly Hot Water Demand Table
Hot Water Demand for Tankless / Instantaneous Water Heaters
Plan Check Submittal Quick Checklist
Floor Diagrams

Section 1

The Plan Check Process

Introduction

Plans and Fees

Plan Submittal

Processing Plans

Construction Inspections

INTRODUCTION

A properly designed food establishment promotes good food safety and sanitation practices. This is accomplished by preventing vermin entry and harborage; providing for ease of maintenance and cleaning; reducing the opportunity for cross-contamination of food, equipment, and utensils; encouraging good handwashing habits; ensuring effective temperature controls for potentially hazardous foods during holding, storage, cooking, and cooling operations; and encouraging other safe food handling practices.

An operator should not only consider the minimum requirements of the California Health & Safety Code when designing a food establishment, but also the specific needs associated with the planned retail food operation. Also recognize that code requirements are minimum standards and may not ensure the best possible conditions for your business.

Properly designed and equipped facilities are easier to maintain, last longer before expensive repairs or equipment replacements are needed, and allow greater flexibility should the facility need to expand or change its operation in the future. Also take into consideration that quality materials and good workmanship are significant factors in constructing a food establishment. A facility operator should strive not just to meet code requirements, but should take a genuine interest in providing a facility that promotes good food safety and sanitation practices.

For example, rather than plan a kitchen hand-sink location as an afterthought (i.e., wherever it fits when all other equipment is taken into account), an operator should consider the critical importance of proper handwashing in preventing disease. It's important to find the best location for the sink considering employee accessibility, opportunities for contaminating hands (e.g., handling raw food products, cleaning vegetables, handling, and keeping the sink from being used improperly).

These plan check and construction requirements are intended to assist those constructing, remodeling, altering, changing equipment, or making repairs to a food establishment. Details are provided on determining when plans are necessary, required information and format for plan check submittal, review of plans by the Environmental Health Division (EHD), construction standards, and required construction inspections. **Please note that nothing contained in this handout precludes compliance with applicable laws or regulations.**

PLANS AND FEES

Plans are required for the following:

- New construction or new food facilities
- Remodeling

Plans may be required for the following:

- Minor remodeling
- Equipment installation or replacement
- Change in the type of food service
- Re-opening a vacant or closed food establishment

Remodeling is any construction or alteration to an existing establishment. This includes installation of equipment, major repairs, or work that alter the facility's configuration or method of operation. A remodel does not include the installation of a food establishment in a new structure, an empty space in an existing building, a space that was not formerly a food establishment, or a food establishment from which all equipment and interior structures have been removed. These situations are considered new construction.

Any required plan check fees are to be paid at the time of plan submittal. The current fee schedule is available from EHD, and may also be viewed on the website at: <http://www.co.merced.ca.us/index.aspx?NID=1740> .

PLAN SUBMITTAL

Plans can be submitted digitally. The submittal shall consist of a complete set of documents on a FLASH/USB drive, a CD/DVD, or through an approved digital download through email. Plans must be approved by the EHD and as required by other agencies (e.g., local building department, fire department, planning department, sewer district, etc.) prior to construction.

Construction prior to plan approval may result in significant fines and/or other penalties. Construction may include grading. Grading cannot start if a septic system is involved.

Plans may be prepared by an architect, draftsman, contractor, or the facility operator, but all plans must be drawn in a professional manner and demonstrate compliance with applicable laws and regulations. The service of a professional experienced in food establishment design is recommended.

Plans must be clearly drawn to scale 1/4" = 1' (recommended) using non-erasable ink or print (no pencil) and contain all of the following information (where applicable):

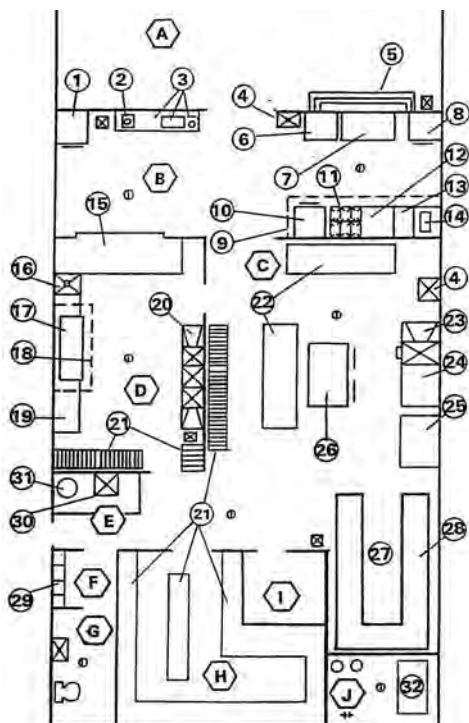

- A Dining Area
 - B Wait Station
 - C Kitchen Area
 - D Dishmachine Area
 - E Janitorial Station
 - F Employee Locker Room
 - G Restroom
 - H Storeroom
 - I Office
 - J Trash Enclosure
 - K Hot Water Demand Worksheet
 - L Mechanical Exhaust Ventilation Worksheet
 - M Tankless Water Heater Worksheet
-
-  Sinks
 -  Floor Drain
 -  Hose Bibb

Each piece of equipment is numbered to correspond with the equipment checklist

1. Scale used and north arrow.
2. Name and address of facility.
3. Name, mailing address, and phone number of facility owner, contractor, person preparing the plans, and contact person.
4. Site layout including location of any outside wash-down areas, dumpsters, and waste storage receptacles (e.g., garbage, rubbish, grease, etc.).
5. Floor plan showing the locations of the following (whether existing or proposed):
 - Food receiving, preparation, display, and storage areas
 - Utensil washing and utensil storage areas (including disposable items)
 - Dry goods storage (paper goods, linen, food, backup, misc. items)
 - Employee changing/locker rooms (including locations where employees store personal belongings)
 - Janitorial supply/equipment storage areas (including janitorial sink, floor mat washing, chemical storage)
 - Restrooms (customer, employee, off-site)
 - Plumbing layout including the location of overhead sewer lines, plumbing fixtures, hose bibs, water heaters, water treatment devices, dipper wells, floor sinks, funnel drains, floor drains, grease traps, grease interceptors, anti-siphon and backflow prevention devices, and chemical feeder systems. (Detail any “cut-outs” used to accommodate indirect waste receptacles and plumbing in outside refuse areas)
 - Electrical layout including the location of electrical outlets, panels, lights, and control boxes. Indicate light intensity (in foot-candles) and lights with shatterproof covers
 - Wait stations
 - Customer self-serve areas including buffets, bulk food sales, beverage counters, salad bars, condiment bars, displays, etc.
 - Manager’s or chef’s office
 - All equipment including but not limited to: tables, shelves, food processing devices, water heaters, ice machines, ice bins, salad bars, display cases, customer self-serve units, beverage machines, condiment stations, stoves, refrigerators, bars, freezers, sinks, dishwashers, cabinets, counters, wait stations, plumbing fixtures, ovens, sneeze-guards, serving lines, produce foggers, steam tables, exhaust hoods, bulk food containers/dispensers, indirect waste receptacles, air curtains, heat lamps, lockers, and water treatment devices
 - Runs of conduit and piping located outside of walls, floor, or ceilings
 - Entryway and delivery doors, French doors, other doors. Indicate self-closing doors and doors protected by an air curtain
 - Pass-through windows, openable windows. Indicate windows with screens.
 - Interior garbage and other waste storage areas
 - Remodel plans must identify all proposed changes, including those to existing structures, room finishes, fixtures, plumbing fixtures, counters, cabinets, and equipment. Also, include a floor plan showing the existing facility.

6. Equipment specifications demonstrating compliance with applicable NSF and Health & Safety Code standards for the intended use. Include manufacturer's specifications (cut-sheets) numbered to correspond to the designations shown on the plans. For equipment not listed by NSF (or custom built units), sufficient information must be provided to show compliance with applicable NSF standards. Include name, address, and phone number of custom fabricators. Underwriters Laboratories (UL Sanitation) and ETL Testing Laboratories listing are acceptable if it demonstrates compliance with the appropriate NSF standards.
7. Equipment schedule showing make and model number.
8. Equipment elevations (specify casters or 6-inch or higher legs meeting NSF standards, or 4-inch or higher integrally coved base), distances to walls and other equipment, and method of installation. This information must clearly demonstrate that inspection and cleaning operations around and underneath equipment can be readily accomplished. If casters are less than 6 inches in height, the equipment must be readily movable by one person.
9. Scale cross-sectional details for any sneeze-guard protection used.
10. Cross-sectional details for the discharge to any indirect waste receptacles. Include the location of any overlying equipment above the receptacle.
11. Mechanical ventilation details for hood systems over cooking equipment and high-temperature dishwashing machines. Provide the following information:
 - Duct details extending to the roof fans, including all elbows and cleanouts.
 - Location of all air diffusers in the kitchen and surrounding areas, including make-up air; specifications on the type of diffuser.
 - Front and side elevations showing hood overhang. Indicate the inner rims of any gutter(s). Show any sidewalls or tapered side panels.
 - Overhead view showing the equipment covered by an outline of the hood (use inner rims of gutters), each make-up air diffuser, exhaust and make-up air ducts, and exhaust and make-up air fan units on the roof.
 - Spacing between pieces of equipment and from nearby walls.
 - Complete and return a *Hood Worksheet* for each ventilation system.
 - See the handout, ***Requirements for Hood Plans***, for complete details.
12. Finish schedule for walls, floors, and ceilings in each room or area, including inside walk-in refrigerator and freezer units. Specify the types of materials and color scheme (e.g., egg-shell white). Provide the following information:
 - Include details/samples for any "accent" finishes.
 - Indicate the type of base and method of coving the wall/floor and toekick/floor junctures; show scale-coving cross-sections at these junctures (including floor-mounted mop sinks or basins).
 - Provide installation details where dissimilar floor materials are joined.
 - Show the exact location of slip-resistant floors that are abrasive or have raised tread patterns. (These floors are only allowed in traffic areas and not underneath equipment.)
13. Submit labeled samples of wall, floor, and ceiling finishes. Include color scheme, accent tiles, and floor cove pieces. (Manufacturer's specification sheet for the proposed finishes may be required.)

14. Provide details on the finishes in dumpster and other outside waste storage areas.
15. Number of proposed employees, seating capacity, and square footage.
16. Method of water supply and sewage disposal.
17. Copy of proposed menu or description of foods/beverages sold. (Include information if facility will be used as a commissary for catering or food vehicles.)
18. For health care facilities, skilled nursing facilities, and hospitals, include a copy of the HACCP plan.
19. Provide a detailed plan for the proper cleaning of any equipment intended for a clean-in-place cleaning method.
20. Provide a detailed plan for the cooling of large quantities of food, where applicable.
21. If remodeling a restroom at an existing facility, include details on how approved restroom facilities will be provided during the construction. Portable toilet facilities are not approved for this purpose.

PROCESSING PLANS

Allow EHD twenty (20) **working** days to review the plans. After the plans are approved, the plans will be retained by this agency and a "plans approved" letter will be mailed to all parties involved. The "plans approved" letter (including any approved amendments) must be kept at the job site during construction until final construction approval.

ANY SUBSEQUENT ALTERATION OF APPROVED PLANS MUST BE APPROVED IN WRITING BY EHD PRIOR TO COMMENCING WORK.

CONSTRUCTION INSPECTIONS

It is advised that you contact EHD at regular intervals to schedule construction progress inspections, or if any questions arise about the project. The contractor and applicant are responsible for scheduling the following inspections:

- **Midpoint inspection:** When work is approximately 50-80% complete with plumbing, room finishes, rough ventilation, and rough equipment installed.
- **Final inspection:** When all work is completed, including hot water supply, ventilation, refrigeration, lighting, and cleaning.

Inspection appointments must be made directly with an inspector at least 24 hours in advance. Inspections will not be conducted if the required building permits are not on site. EHD must issue a final construction approval before opening or using new or remodeled areas, including stocking with food items (unless specifically permitted in writing from the inspector).

During remodel work, if the business remains open, sufficient protective measures must be taken to prevent the contamination of food, food contact surfaces and equipment. Failure to do so will result in closure of the establishment until remodeling activities are completed.

Section 2

Summary of the Plan Check Process

Application, Plans and Plan Check Fee
Review of Plans
Construction Midpoint Inspections
Final Inspection
Permit Issuance

***SPECIAL NOTE** for water wells and septic users

The California Health & Safety Code requires a valid health permit to operate a retail food establishment. These establishments include restaurants, bars, markets, supermarkets, bakeries, cafeterias, soup kitchens, coffee houses, liquor stores, butcher shops, commissaries, candy stores, snack bars, delicatessens, licensed health care facilities, skilled nursing facilities, hospitals, mobile food vehicles, food carts, or any fixed facility where food is sold or given away at the retail level. The law contains minimum standards concerning facility design and construction, equipment specifications, and food handling. These requirements are intended to make sure the consumers' food supply is pure, safe, unadulterated, and held and prepared under sanitary conditions and that food establishments are clean, free from vermin and insects, and kept in a state of good repair.

This handout is a summary of Merced County's requirements and is meant as a guideline to use in obtaining a permit to operate a food establishment. It is subject to change without notice. While intended primarily for new construction or extensive remodeling projects, it also serves as a helpful guide for existing retail establishments, since structural and equipment requirements also apply to currently operating facilities.

The following is a chronological summary of the plan check process:

STEP 1: APPLICATION, PLANS, AND PLAN CHECK FEE

Submit completed plan review application, a digital set of plans, equipment specification sheets, other required materials, a menu (if applicable), and the applicable plan check fee. **Please note that inadequate plans will not be approved and may delay the issuance of a health permit.**

STEP 2: REVIEW OF PLANS

Environmental Health Division (EHD) has twenty (20) working days to review, reject or approve the plans. The plans will be reviewed for compliance with applicable requirements. If the plans are not approved, you will be notified as to the changes and/or additional information required in order to receive approval. Construction can commence once the plans are approved and you have received a building permit from the local building department. Also obtain any other required approvals, including local planning, fire, and sewer authorities.

STEP 3: CONSTRUCTION MIDPOINT INSPECTIONS

During construction, EHD will conduct at least one midpoint inspection. The contractor and applicant are responsible for scheduling all required inspections. Construction inspections will not be scheduled if the appropriate building permits are not on site. A midpoint inspection must be scheduled when room finishes are completed and plumbing, ventilation, and equipment are in place. Schedule this inspection at least 48 hours in advance.

STEP 4: FINAL INSPECTION

Upon completion of construction and before opening, a final inspection will be conducted to verify that compliance with all requirements has been accomplished. A final inspection must be scheduled when

100 percent of the construction is completed, including all finishing work and utility hook-ups. Schedule this inspection at least 48 hours in advance. It is recommended that you allow sufficient time between the final inspection and the facility's projected opening date should any corrective work become necessary.

STEP 5: PERMIT ISSUANCE

Once construction is completed to the satisfaction of EHD, a permit to operate will be issued upon payment of the permit fee and any outstanding plan check balance. Operating without a valid health permit will subject the business to substantial penalties and it may be required to close.

***SPECIAL NOTE for water wells and septic system users**

For proposed establishments served by an on-site well, the issuance of a public water system permit or approval of a CURFFL exemption are required prior to issuance of a permit to operate the establishment. For existing wells, analysis of the well water for total coliform bacteria and E. coli (or fecal coliform) by a State certified laboratory shall be submitted prior to starting the plan check. The water sampler shall meet the sampler requirements in CCR, Title 22 public water system regulations.

Applicants for establishments with an existing on-site septic system shall submit a plot plan indicating the location of any well on the parcel, the location and capacity of the septic tank, and the location and length of the leach lines. Both sides of the septic tank shall have been pumped and the septic system evaluated within the last five years, as demonstrated by a document from a permitted septic pumping company. These documents shall be submitted prior to issuance of a permit to operate the establishment.

If the well and/or septic system have not been constructed, the applicant shall submit a plot plan indication all proposed surface features and the location of the well, septic tank, leach lines, and 300% leach field replacement area. The plot plan shall also indicate the location of any septic system on each adjacent parcel. This document shall be submitted prior to starting the plan check.

Section 3

Construction and Equipment

Requirements

Floors

General

Coving

Details of Integral Coved Floor Base

Sheet Vinyl Floor

Tile Floor

Floor Drains

Anti-slipping Agents

Dissimilar Materials

Metal Coving in Walk-In Units

Grout

Pest Control

Grease Trap Covers

Bars

Walls and Ceilings

General

Wet Areas

Flame-resistance

Acoustical Ceiling Tiles

Suspended Ceilings

Bars

Conduit and Piping

FLOORS

General

Appropriate floor, wall, and ceiling finishes promote good sanitation. Sanitation is an important component of public health protection. Disease outbreaks have been linked to harmful micro-organisms growing on finishes. The easier it is to monitor and clean these finishes, the more likely it is that the task will be performed regularly and properly. This is important, since failure to keep a food facility clean is a cause of vermin (rodent and insect) infestations. Additionally, a leading cause of workers compensation injuries is slips and falls. Keeping floors clean and dry, and also proper footwear for employees, can help reduce these types of costly accidents.

Except in areas used exclusively for dining or point-of-sale, floors must be smooth, durable, nonabsorbent, impervious to water, grease, and acid, and of easily cleanable construction. Acceptable floor materials include the following:

- Quarry tile, ceramic tile
- Sealed curbed concrete
- Seamless poured epoxy minimum 3/16-inch thick. (**Note: Seamless poured epoxy is not a paint.**)
- Commercial-grade sheet vinyl (**no felt backing**) at least 0.080-inches thick, with heat-welded seams, may be suitable for some applications if also consistent with manufacturer's specifications. Where sheet vinyl is used as the floor material, a cove backing (cove stick) must be used at the wall/floor and toekick/floor junctures.

Vinyl composition tile (VCT) with vinyl or rubber-base coving is not recommended and will only be considered in those areas where coving (as described below) is not required. Carpet and wood are only allowed in areas used exclusively for dining or point-of-sale.

Coving

Coving is the floor material found at the base of walls (wall/floor junctures) and equipment toekicks (toekick/floor junctures). Toekicks include the bases of counters, cabinets, salad bars, and other floor-mounted equipment (including floor-mounted mop sinks) that is not placed on approved legs or casters.

In most areas of a food establishment, it is required that the floor material extends integrally up the walls and toekicks as the coving. (Topset coving is not allowed in any area requiring integral coving.) For example, in the following areas the floor material must extend integrally up the walls and toekicks at least 4-inches with a minimum 3/8-inch radius at the wall/floor and toekick/floor junctures: (**The foot of the cove base has to extend out to ¼ inch**). See Floor Diagrams in Section 10 Forms.

- Food preparation, storage, handling, and packaging areas
- Utensil washing and storage areas

- Interior waste disposal areas (garbage, refuse, grease)
- Restrooms
- Handwashing areas
- Janitorial facilities
- Walk-in refrigerator and freezer units (inside and outside)
- Bars (employee side)
- Customer self-serve areas where non-individually prepackaged foods or beverages are sold or dispensed (e.g., salad bars, buffets, bulk food sales, beverage stations)
- Employee change and storage areas
- Wait stations

Integral coving is not required in areas used exclusively for dining, point-of-sale, or the storage of food or utensils contained in the original **un-opened** containers. In un-opened container storage areas, it is recommended that integral coving still be provided for both sanitary reasons and because it allows the operator more options should future storage needs or use of these areas change.

Food preparation includes the making of ice, combining of ingredients to make beverages, partitioning, packaging, washing produce, and cooking operations. Utensils include kitchen equipment, disposable utensils, and take-out containers. For example, an area used to store opened boxes of take-out drink cups must have finishes appropriate for a utensil storage area. For diagrams of flooring click [HERE](#).

Floor Drains

Floor drains are required in, but not limited to the following areas:

- Where floors are water-flushed for cleaning (e.g., kitchens generating grease, meat or fish handling areas, produce trimming areas, refuse disposal areas, dishwashing areas, bars)
- Where pressure spray methods are used for cleaning.
- Where Type I hoods without built-in cleaning systems are in use.

Where floor drains are provided, the floor surface must have a slope to the drains. The drains are to be located for ease of inspection and maintenance. They must not be located inside walk-in refrigerator or freezer units, in food or utensil storage rooms, inside or underneath cabinets or counters, or in inaccessible locations. Floor drain grates must be provided and installed flush with the surrounding floor.

Regardless of the establishment, the floor construction must not allow the accumulation of standing water, grease, or food debris—or pose any sort of slipping or tripping hazard.

Anti-slipping Agents

Anti-slipping floor agents, such as abrasives or raised tread patterns, are restricted to traffic areas only. Flooring in non-traffic areas, under equipment, in walk ins, and at the wall/floor and toekick/floor junctures, must be smooth. If the degree of roughness in traffic areas is deemed excessive, high-pressure hot water cleaning systems (with floor drains) will be required.

Dissimilar Materials

Where dissimilar floor and/or coving materials are joined, this juncture must be easily cleanable, durable, and have a smooth integral transition.

Metal Coving in Walk-in Units

Where metal coving is installed inside walk-in refrigerator or freezer units with a metal floor, the coving must be installed in a smooth transition with a minimum 3/8-inch radius at the wall/floor junctures. The metal coving is not to be top set installed.

Grout

Where floor grout is used, an acceptable grout additive must be included with the grout to make it resistant to grease, oil, acid, and water. Acceptable additives include epoxy, silicone, and polyurethane.

Pest Control

For pest control purposes, particularly in storage areas, consider providing a 12-inch wide white-colored stripe on the floor at the wall/floor junctures. This is a useful aid to monitor for rodents and other pests.

Grease Trap Covers

If a grease trap has to be installed in a traffic area, the grease trap lid must be installed flush with the floor. The cover must also be readily accessible for inspection and cleaning. As a rule, grease traps will be required to be installed outside of the facility.

Bars

Bars are considered a wall surface and as such the floor material must extend up the bar structure (employee side) at least 4-inches with a minimum 3/8-inch radius at the bar/floor junctures.

See Floor Diagrams in Section 10 Forms

WALLS AND CEILINGS

General

Durable, easily cleanable finishes are easier to clean and better able to withstand repeated cleaning operations. Light-colored wall and ceiling finishes are recommended since they aid cleaning by providing a means of monitoring sanitation by readily revealing dirt, grease, rodent rub marks, and insect excrement.

Walls and ceilings are required to be smooth, durable, nonabsorbent, and easily cleanable in all rooms or areas **except** those used exclusively for:

- Bars serving only alcoholic beverages (not including the area around sinks or the backside of the bar structure—employee side)
- Dining
- Offices
- Storage of food in original unopened containers
- Point-of-sale for individually prepackaged items

Restrooms used exclusively by customers or patrons need not have light-colored finishes, but it is recommended as an aid to monitoring sanitation. All other requirements apply to these restrooms. Acceptable wall and ceiling finishes include the following:

- Gloss, semi-gloss enamel, or epoxy paint on an acceptable smooth surface (e.g., no plaster texture, or “orange peel” finish).
- FRP paneling
- Stainless steel
- Smooth ceramic tile
- For ceilings, smooth washable vinyl ceiling tiles are also acceptable.

Exposed brick, unsmoothed concrete block, plaster-textured paint, rough concrete, Marlite, varnished wood, wood paneling, murals, exposed open rafters, exposed studs, and fissured ceiling tiles are not acceptable finishes.

Wet Areas

Certain finishes, particularly paint, are unsuitable for areas subject to excessive moisture (e.g., dishwashing areas, around janitorial sinks, bar sinks, etc.). The walls above, behind, and around sinks in dishwashing areas, and other locations subject to moisture must be covered with durable waterproof materials (e.g., FRP, stainless steel, ceramic tile). Other requirements include:

- Around hand-sinks, the waterproof materials must extend from the top of the coved base (wall/floor or toekick/floor junctures) to at least 6 inches above the backsplash.

- Walls at/near other sinks must have a waterproof finish extending from the cove base to at least 8 feet above the floor. This includes utensil sinks, janitorial sinks or basins, and food preparation sinks.
- Walls in dishwashing areas and produce trimming areas must have a waterproof finish extending to at least 8 feet above the floor.
- Walls in areas where floors are cleaned using high-pressure sprayers must have a waterproof finish extending to at least 8 feet above the floor.
- Walls in restrooms around plumbing fixtures (e.g., toilets, urinals, sinks) must have a waterproof finish extending to at least 4 feet above the floor.
- In any area, the greatest applicable height requirement for a waterproof finish will apply. The finishes above the waterproof finish must meet all other applicable requirements.

Flame-resistance

Local fire departments may have additional requirements regarding the type of wall material around cooking equipment. Typically, a stainless steel or ceramic tile finish is required. Contact the fire department for details.

Acoustical Ceiling Tiles

If you wish EHD to consider approving an acoustical ceiling tile, submit a sample for review. Smooth, washable vinyl acoustical ceiling tiles are acceptable in most applications.

Suspended Ceilings

If possible, it is recommended that facilities utilize a solid ceiling in kitchens rather than a suspended ceiling. The “dead” space above suspended ceilings can provide extensive vermin harborage. Ceilings more than 10 feet in a warehouse-type facility are not mandated to have a drop in ceiling (warehouses, janitorial rooms).

Bars

Areas used exclusively for the preparation and serving of alcoholic beverages are not required to have smooth, durable, light-colored finishes for the walls and ceiling. However, areas around bar sinks and areas used for other types of food service (including other beverages) will be required to have finishes as described in wet areas. This usually includes the entire employee side (and underneath the overhang) of the actual bar structure.

CONDUIT AND PIPING

All plumbing, electrical, and gas lines must be installed within the walls, floors, and ceilings to the greatest extent possible. This requirement is intended to facilitate cleaning and eliminate vermin harborage. Where this is not possible, all runs must be spaced at least one inch off the walls and ceilings and at

least 6 inches above the floor. Conduit and spacers must be constructed and installed to be durable and easily cleanable. Minimize horizontal runs of conduit and piping wherever possible. Other requirements include:

- Where conduit or pipes enter a wall, ceiling, or floor, the opening around the lines must be tightly sealed and made smooth, durable, and easily cleanable. Multiple runs of clusters outside walls must be encased in approved runways or other approved sealed enclosures.
- Conduit or pipelines must not be installed where they could become a tripping hazard (e.g., across aisles, traffic areas, etc.).
- Overhead sewer lines are not allowed over areas where food, utensils, equipment, or clean linens may be present.
- Exposed flexible type conduit is not allowed on the outside of walls or ceilings unless the conduit has a smooth easily cleanable surface.
- The exterior of ventilation ducts installed in areas requiring a smooth, easily cleanable ceiling finish must be smooth and easily cleanable.

Section 4

Equipment – General Requirements

Standards

Installation

Elevations

Acceptability of Intended Use

Counters and Cabinets

Backflow Prevention for Carbonators

Copper and Copper Alloys

Live Shellfish Tanks

Built-In Temperature Measuring Devices

Produce Foggers / Misters

Energy Efficiency

Mechanical Ventilation for Cooking Equipment

Mechanical Ventilation Sample Diagram

General

Hood Materials

Canopy-Type Hoods

Non-Canopy Type (Ventilator) Hoods

Make-Up Air

Short-Circuiting Hood Systems

Fire Extinguishing Systems

Grease Filters / Extractors for Type I Hoods

Ducts

Caster and Quick Disconnects

Wood Burning Ovens

Multiple-Stack Conveyor-Type Ovens

Conveyor-Type Dishwashers

Hood Overhang

Clearances

UL Listed Hoods

Performance Testing
Exempt Cooking Equipment
Improved Hood Performance

Refrigeration and Freezer Units

General
Additional Requirements for Walk-In Units
Condensate
Merchandisers
Espresso Machines

Ice Machines

Customer Self-Service Equipment

Sneeze Guard Guidelines
Cafeteria Service
Self-Service at Both Sides
Self-Serve Container for Ready-To-Eat Foods

Equipment Approved for Self-Serve Soda Dispensers

Push Button Type
Approved Lever Type

EQUIPMENT – GENERAL REQUIREMENTS

Standards

Equipment must be commercial-grade and comply with applicable NSF and Health & Safety Code standards. Underwriters Laboratories (UL Sanitation) and ETL Testing Laboratories listings are also acceptable if compliance with applicable NSF standards is demonstrated. **Residential equipment is not allowed.** Equipment must be made of nontoxic, non-corrodible materials, and be constructed, installed and maintained to be easily cleanable and exclude vermin. The design and installation must also allow ease of cleaning under and around the equipment and adjacent surfaces.

Installation

Equipment is to be sealed to adjacent walls and equipment or suitably away from adjacent walls and equipment so as to facilitate cleaning of the equipment and surrounding surfaces. Provide at least 6-inches of space between the equipment and wall for every 4 linear feet of equipment length. For example, an 8 foot long range should be spaced at least 12-inches from the wall. Also provide sufficient spacing between equipment to allow for ease of inspection and cleaning (minimum 6-inches). These spacing requirements can be reduced if the equipment is on casters. If casters are used, allow enough space for ease of inspection.

Elevations

Floor mounted equipment must be placed on easily cleanable casters (readily movable by one person) or 6-inch or higher legs meeting NSF standards, or be completely sealed in position on a 4-inch or higher integrally covered base or curb. Wider equipment may require greater height requirements to facilitate cleaning underneath.

Casters are the recommended means of insuring sanitation for cooking and many other types of equipment. Casters less than 6-inches in height can only be used if the equipment is readily movable by one person. With gas-fired equipment, casters require the use of appropriate heavy-duty quick-disconnect gas lines (with safety tether). Some fire departments do not allow cooking equipment to be placed on casters. Check with the local fire department for further information.

If tabletop mounted, the equipment must be on legs at least 4-inches high, readily movable (i.e., maximum weight of 80 pounds), or sealed in an approved manner.

Do not use skirting at the base of equipment, except that skirting may be used on display units located in a customer display area if all food items are individually prepackaged.

Acceptability of Intended Use

Equipment listed by NSF may not be suitable for the intended use. For example, some NSF listed hot dog warmers are not designed to protect the product from customer contamination. These units are meant for serving by an employee rather than for customer self-service. Another example is merchandiser refrigerators, which are for use on display floors, not in kitchens.

Always verify with EHD that equipment is acceptable for the intended use by submitting manufacturer's equipment specification sheets.

Counters and Cabinets

Counters and cabinets are considered pieces of equipment and must comply with applicable NSF and Health & Safety Code standards. They must be designed for durability, ease of cleaning, and to exclude vermin harborage. The most common construction materials are stainless steel or plastic-laminate. Laminated units must be fully plastic-laminated inside and out, including the underside of counter tops. It is recommended that cabinets with interior laminate finishes be a light-color to aid in monitoring for pests. Counters or cabinets constructed of painted or varnished wood are not approved for the food preparation areas. In order to promote sanitation, such units must be placed on 6-inch or higher legs, casters, or an integrally coved 4-inch or higher base.

Equipment (e.g., under counter dishmachines, ice machines, or bulk food bins) must be set back at least 2-inches from the drip line of the overlying surfaces above.

Backflow Prevention for Carbonators

The potable water supply connected to beverage machine carbonators must be protected by a listed, properly installed reduced pressure backflow prevention device.

Copper and Copper Alloys

Copper and copper alloys may not be in contact with low pH materials (e.g., carbonated water), except when used in the brewing of beer.

Live Shellfish Tanks

Tanks used to keep live molluscan shellfish intended for human consumption must be provided with an approved treatment and filtration system. This system must ensure the bacteriological quality of the water is kept within acceptable limits at all times (i.e., no detectable levels of coliform bacteria). The system must include the following:

- Filtration
- Treatment (e.g., UV light)
- Refrigeration (to keep the water below 45°F)
- Pump

- An operating plan that includes routine maintenance procedures and regular (at least monthly) independent testing of the water for coliform bacteria.
- Each species of molluscan shellfish must have its own separate tank and filtration/treatment system that is not interconnected with any other species of shellfish or other tank, including those used for fish.
- **A HACCP plan shall be submitted for approval by the State Department of Health Services.**

Built-in Temperature Measuring Devices

Built-in or permanently affixed temperature measuring devices are required inside equipment used to hold hot or cold potentially hazardous foods. For a refrigeration unit, this device must be located in the warmest part of the unit.

Produce Foggers/Misters

Produce foggers/misters must be designed and installed so as to be easily cleaned and sanitized. Reservoirs for holding the water are prohibited.

Energy Efficiency

Energy costs are a major expense for most retail food operations. The following websites contain information that may help you reduce energy costs: www.fishnick.com.

MECHANICAL VENTILATION FOR COOKING EQUIPMENT

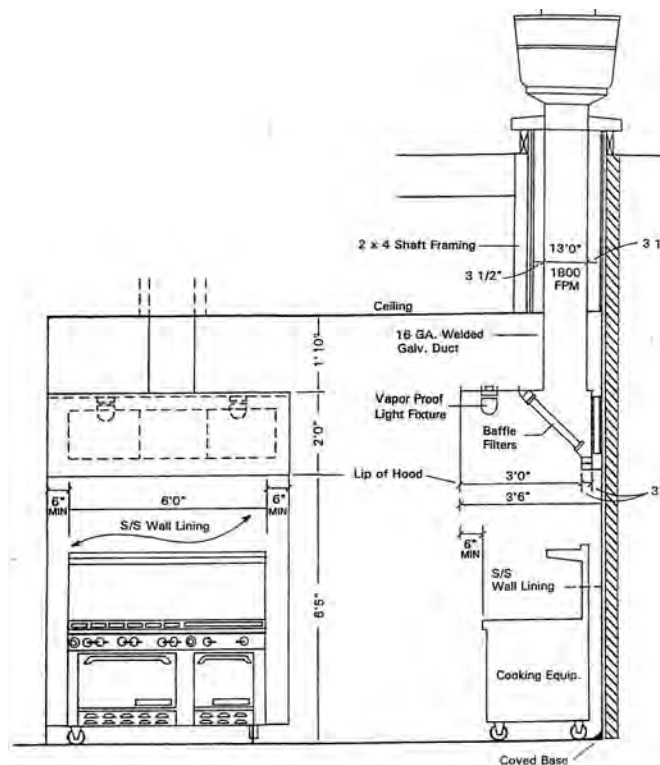

Mechanical Ventilation System Sample Diagram

General

Proper ventilation of cooking equipment provides for employee comfort; protects equipment, finishes, and food from excess heat or moisture, which can cause their deterioration; and removes moisture and grease which can encourage insect infestations and result in slip and fall injuries. Where large amounts of grease vapors are produced, the mechanical ventilation system serves to remove grease from the air stream preventing its accumulation in the duct system. This reduces the risk of grease fires.

Mechanical ventilation hood systems are required above all high-temperature dishwashing machines (except under-counter models) and cooking equipment, including ranges, griddles, broilers, steam jacketed kettles, ovens, large popcorn machines, deep fryers, barbecues, rotisseries, and any equipment that produces cooking odors, steam, grease, heat, or vapors. Requirements for mechanical ventilation systems include:

- Ventilation systems must be constructed and installed in accordance with the locally adopted Uniform Mechanical Code (UMC).
- Joints and seams are to be tightly sealed and easily cleanable. Riveted seams are not acceptable.
- Any penetrations of the hood canopy or duct must be done using UL-listed materials and methods.
- Grease troughs not associated with the filter bank are not recommended, but when provided they must slope to an approved drip pan. Grease troughs and drip pans must be easily cleanable.
- Food heating or warming devices (e.g., cheese-melters, plate warmers) and shelving that are installed above other equipment beneath an exhaust hood may create an air flow obstruction to the proper ventilation of the cooking equipment for which the hood was designed. The installation of these devices is subject to evaluation and approval, and must be considered as part of the ventilation design.
- Hoods less than one foot from walls or ceilings must be flashed solidly with approved materials.
- Ventilation must be to the outside (e.g., no “ventless” or “ductless” hoods).

Hood Materials

Hoods constructed of stainless steel must have a thickness of No. 22 gauge. If copper is used, the copper sheet is to have a weight of at least 24 ounces per square foot. Galvanized or painted materials are not acceptable hood materials.

Canopy-type Hoods

The lower lip of canopy-type hoods must be no more than 4 feet above cooking surfaces and at least 6½ feet above the floor. The hood must overhang or extend a horizontal distance not less than 6-inches beyond the outer edges of cooking surfaces on all open sides as measured from the inside edge of the hood. Greater than 6-inch overhang is often required depending on the type of equipment used. For example, some ovens may require a 3 foot overhang; char broilers require at least a 12-inch overhang. See the handout, **Requirements for Hood Plans**, for specific overhang requirements.

Non-canopy-type (Ventilator) Hoods / Backshelf Hoods

Non-canopy hoods may be approved if they are engineered and constructed so as to comply with the minimum exhaust air velocity requirements and comply with manufacturers specifications. Shielding at the ends of the hood may be necessary to prevent interference from cross drafts. These types of hoods are not suitable for certain types of cooking equipment such as woks, char broilers, ovens, or ranges.

Make-up Air

Filtered make-up air must be provided at least equal to that amount which is mechanically exhausted. For example, a hood exhaust system drawing 3000 cubic feet of air per minute (cfm) must have a make-up air source providing 3000 cfm. Windows and doors are not to be used for the purpose of providing make-up air. The location and design of make-up air diffusers must also take into account preventing cross-drafts or other interferences with the hood operation. A single interlocking switch is required for operating the hood exhaust and its make-up air source.

Make-up air diffusers must facilitate the functioning of the exhaust hood system. Four-way diffusers are not allowed less than 10 feet from any hood system unless the air stream does not blow directly toward the hood. It is recommended that diffusers closer than 10 feet from hood systems be the perforated type.

Short-circuiting Hood Systems

Short-circuiting hood systems or other types where the make-up air discharges inside the hood canopy or "capture zone" will not be approved.

Fire Extinguishing Systems

Fire extinguishing systems may be required by local fire or building departments. They must be installed so as to allow easy cleaning of the hood and duct systems. Horizontal piping or conduit within the hood is prohibited.

The fire department may have requirements for the minimum separation between deep fat fryers and open-flame cooking equipment.

Grease Filters/Extractors for Type I Hoods

Hoods with grease filters are required to use baffle-type filters with the baffle slats oriented perpendicular to the floor. Mesh-type filters are not allowed. Filter handles are required for hoods with grease filters unless the filters are designed for in-place cleaning. Other types of grease removal systems will be evaluated on a case-by-case basis. Other requirements include:

- The distance between the bottom edge of the filter and the cooking surface must be at least 2 feet, except for exposed fire or charcoal char broilers where the minimum distance must be 3½ feet.
- Baffle filters must be installed at an angle of 45-90 degrees from the horizontal.

- Hoods must provide air velocity in the range of the filter's rated capacity. The allowable range is typically 250-350 feet per minute (fpm) with 300 fpm the recommended velocity for most filters. Other proposed velocities will be evaluated on a case-by-case basis.
- Grease filters must always be in place and the fire suppression system fully functional when cooking equipment is turned on.

Ducts

Ducts for Type I hoods must be sized so the velocity of exhausted air is 1500–2500 fpm. There must be at least one duct per 12 lineal feet of hood length, or fraction thereof. Ducts shall be installed no closer than 6 feet apart. For example, a 14 foot long hood would be required to have at least 2 ducts. Ducts must terminate outside the building in an approved manner. Ductless/ventless hood systems are not allowed.

Caster and Quick-Disconnects

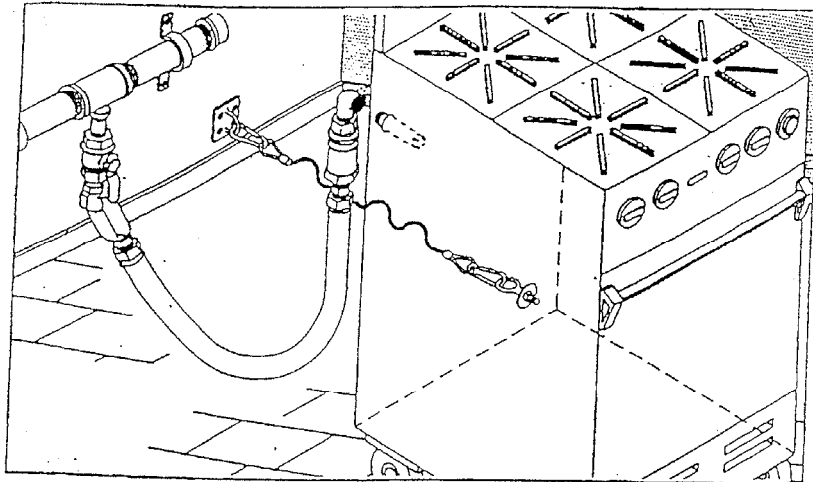

**Heavy Duty Quick-Disconnect
Flexible Gas Line with Keeper Chain**

If allowed by the local fire department, it is recommended that approved 6-inch high casters with approved tether devices be provided for cooking equipment to facilitate cleaning operations. When casters are used, approved heavy-duty, quick-disconnect, flexible gas lines must be provided. Casters must allow for ready inspection and maintenance operations. If casters are not intended for use, detail the means for installing equipment that will allow for ease of inspection and maintenance.

Wood Burning Ovens

Wood burning ovens require a separate ventilation system with a Type I canopy hood. The hood must overhang the front of the oven at least 18-inches and sides of the door at least 6 inches. The minimum distance from the top of the oven-duct to the filter is to be at least 12-inches.

Multiple-Stack Conveyor-type Ovens

For multiple-stack conveyor-type ovens, the hood must overhang the conveyor belt apparatus at least 6-inches. The hoods must overhang the oven openings and side doors by at least 12-inches.

Conveyor-type Dishwashers

If pantleg hoods are to be used for conveyor-type dishwashers, the hood overhang at the dirty dish end must be at least 6-inches with an exhaust rate of at least 300 cfm, and at the clean dish end at least 10-inches with an exhaust rate of at least 500 cfm.

Hood Overhang

In designing hoods with at least the minimum required overhang, take into account not only the actual size of the equipment under the hood, but also cleaning and installation requirements of the equipment (i.e., piping, gas lines, quick-disconnect lines, valves, wiring, etc.) which may make the effective size of equipment greater than the dimensions specified by the manufacturer.

Minimum hood overhangs range from 6-inches up to several feet depending on the type of equipment. See the handout, ***Requirements for Hood Plans***, for complete details on hood overhang requirements. In general, increasing hood overhang improves hood performance.

Clearances

Unless on casters, provide at least 6-inches of clearance between pieces of equipment under the hood and between the equipment and walls. When sizing hood overhang, take these clearances into consideration so the minimum overhang requirements will be met. Reduced clearances may be allowed if adequate methods for cleaning and inspection are provided (e.g., casters).

UL Listed Hoods

If the hood system is calculated based on a UL listing rather than Uniform Mechanical Code (UMC) requirements, provide documentation (i.e., UL placard) that the specific model of hood is UL-listed for ventilation. Documentation is subject to verification and must include the model specific UL criteria including exhaust volume, filter airflow rates, hood overhang (which may be greater than UMC), make-up air, duct details, and any equipment or other limitations. Where the UL exhaust rate differs substantially from the UMC rate, EHD reserves the right to require the higher rate.

Performance Testing

The installation, including air flow, filter velocities, grease channel slopes, etc., must be approved by EHD before a hood is placed into service. EHD will require a hood balance report (including make-up air) from a licensed mechanical contractor as part of the inspection process.

Exempt Cooking Equipment

Typically, EHD will only consider an exemption from mechanical ventilation for the following cooking equipment:

- Equipment with a maximum temperature of 250°F (thermostatically controlled).
- Electric convection ovens (12 kilowatts or less) used for baking bread only.
- A single piece of equipment (e.g., ovens) weighing 80 pounds or less, isolated from a cook line and that does not produce excessive grease, soot, or vapors.

Any piece of equipment causing sanitation or other problems will require proper mechanical ventilation. Building or fire departments may still require mechanical ventilation, **even if exempted by a State or Local Health Department.**

Improved Hood Performance

With some additional planning, you can significantly increase the performance of your hood system, by doing the following:

- Placing equipment as close to the back wall as possible.
- Using tapered side panels or sidewalls.
- Increasing hood overhang.
- Avoiding using island-type hood systems.
- Not installing any four-way diffusers near a hood system.
- Proper placement and design of air diffusers.

In addition to improving hood performance, energy efficiency can also be greatly improved with careful planning and design. For further information on improving hood performance visit the following websites:

www.pge.com/fstc

www.fishnick.com

www.melinkcorp.com

REFRIGERATION AND FREEZER UNITS

General

Refrigerator and freezer units must be adequate in size and cooling capacity to accommodate the storage needs of the establishment. These needs should also take into account the cooling and thawing of potentially hazardous foods, and catering capacity, where applicable. To prevent the growth of harmful bacteria, refrigerators and freezers must be able to maintain proper temperatures under all operating conditions. These include repeated opening of doors during peak use and high ambient temperatures resulting from proximity to cooking equipment. The ability to maintain proper temperature also helps prolong the shelf life and flavor of foods, particularly perishable products. An excess of capacity is recommended, as it is sometimes difficult to predict the long-term storage needs of a food business. Other requirements include:

- Capable of operating so as to maintain refrigerated foods at or below 41°F and frozen foods in a frozen state at all times. Most frozen food processors recommend their products be kept at temperatures well below freezing (32°F). Ice or passive cooling methods alone are not approved methods for keeping potentially hazardous foods cold.
- Constructed for commercial use with smooth, nonabsorbent, and easily cleanable surfaces. Residential refrigerator or freezer units are not allowed.
- Provided with shatterproof light-covers and accurate, readily visible thermometers (placed in the warmest part of the unit).
- Provided with commercial-grade non-corrodible metal or plastic shelving that allows for air circulation and ease of cleaning.
- Condensate waste must drain to an evaporator or to the sanitary sewer via an indirect waste receptacle (i.e., floor sink or funnel drain with at least a one-inch air gap). Condensate waste may not drain to the ground or into storm sewer drainage system.
- Located inside in an approved area of the building.
- Cooling coils and related electrical, drainage, and refrigerant lines must be installed in a safe and easily cleanable manner. Drainage and refrigerant lines must be constructed of nontoxic materials or properly insulated and covered with an approved, easily cleanable, nontoxic material.
- Provided with readily visible, built-in or permanently affixed thermometers located in the warmest part of the unit.

Additional Requirements for Walk-in Units

- Unless all items are in the original unopened containers, the floor material must extend integrally up the walls (outside) at least 4 inches with a minimum 3/8-inch radius at the wall/floor junctures. When planning to use an NSF unit, make certain it is one provided with an acceptable floor as described above.
- Except in warehouses, the top of walk-in units must be flashed **or provided with a barrier** to nearby walls and ceilings. Where flashing is installed, a means of access for inspection and cleaning must be provided. The areas on top of a walk-in unit may not be used for storage, including in warehouses.
- Floor drains, floor sinks, and funnel drains must be located outside walk-in units.

- Refrigeration or freezer units that do not open directly into the establishment are not allowed. This applies to existing units as well—they are not grandfathered in.

Condensate

Condensate from refrigeration and freezer units must drain via gravity into an approved, readily accessible indirect waste receptacle or an evaporator. Pumping the condensate waste is not allowed.

Merchandisers

Merchandisers are approved for pre-packaged foods only and can be used only in display sales areas. They are not to be used in kitchens, food preparation areas, or storage areas. Please note that some merchandiser units are not approved by the manufacturer for use with potentially hazardous foods.

Espresso Machines

Where an espresso machines is used, an adequately sized refrigerator must be provided nearby for the storage of dairy products.

ICE MACHINES

Ice machines are considered food preparation equipment. They must be located inside the building near a handwashing sink, and in an easily cleanable, well-lit, and well-ventilated area. They must drain to the sewer via readily accessible indirect waste receptacles (i.e., floor sink or funnel drain). Surrounding wall, floor, and ceiling finishes must be smooth, durable, nonabsorbent, and easily cleanable. The walls and ceiling must also be light-colored. The surrounding floor material must extend integrally up the walls at least 4 inches with a minimum 3/8-inch radius at the wall/floor junctures. Ice machines located outside or other unapproved locations are not grandfathered in.

CUSTOMER SELF-SERVE EQUIPMENT

Customer self-serve equipment includes salad bars, buffets, bulk-food dispensers, self-serve beverage units, unpackaged pastry cases, etc. Displays and service of unpackaged foods, utensils, and food contact surfaces must be protected from contamination during all anticipated operating conditions. This includes shielding so as to intercept a direct line between the customer's mouth and the food, utensils, and food contact surfaces. Another option is display or dispensing from approved, sealed, self-serve dispensers. Other requirements include:

- Customer self-serve containers must be designed to minimize the degree of customer handling and exposure.
- Approved sneeze guards must protect utensils, food preparation equipment, and food preparation areas at cafeterias, buffets, salad bars, etc.

- Self-serve machines that dispense ice or beverages must be designed with extended angled levers or push buttons.
- Typically, customer self-serve areas are considered food-preparation areas and must have acceptable wall, floor, and ceiling finishes, and suitable equipment meeting applicable NSF and Health & Safety Code standards. Self-serve counters must have legs, casters, or an integrally covered base.
- Where lids are proposed for protection rather than sneeze guards, the lids themselves must function as approved sneeze guards during all anticipated operating conditions.
- Sneeze-guards must be constructed to NSF standards (e.g., no exposed, painted, or varnished wood can be used).

CAFETERIA SERVICE

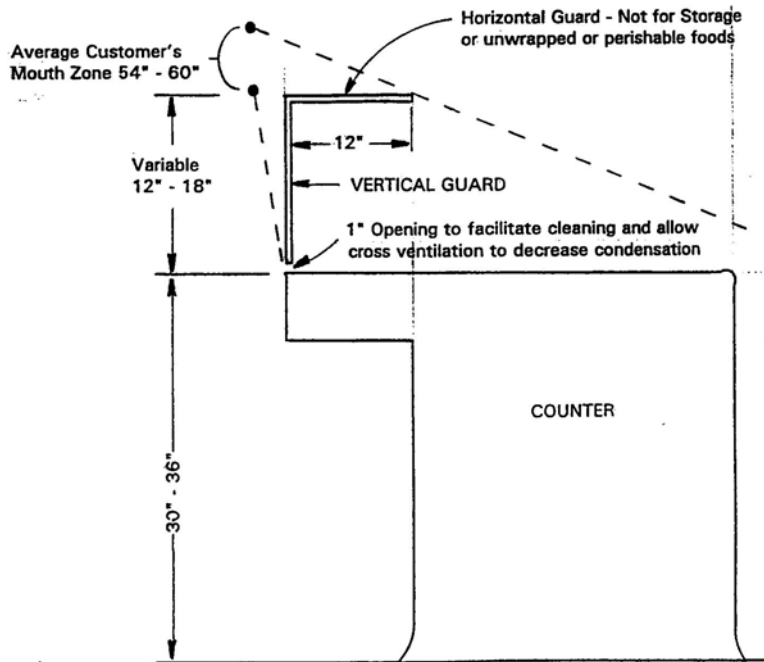

Note: For lower table heights, the vertical guard should be higher and the horizontal guard should be widened.

SELF-SERVICE AT BOTH SIDES

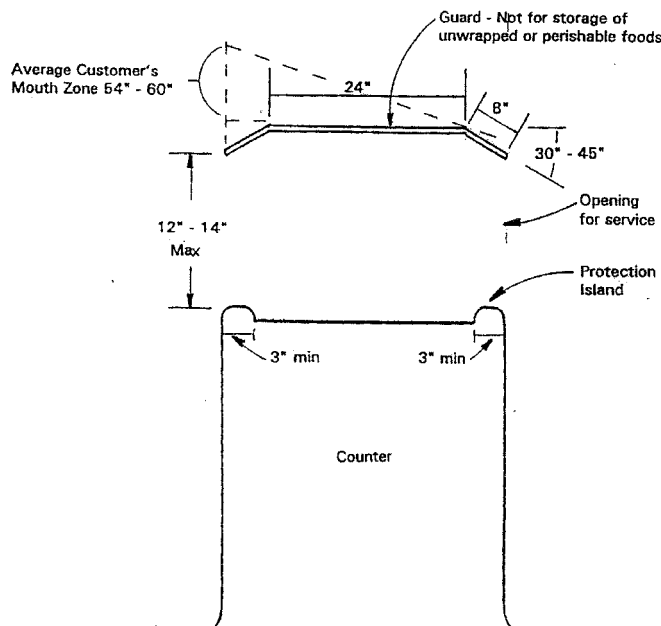

The elimination of tray slides increases the service opening by allowing closer customer contact.

SELF-SERVE CONTAINER FOR READY-TO-EAT FOODS

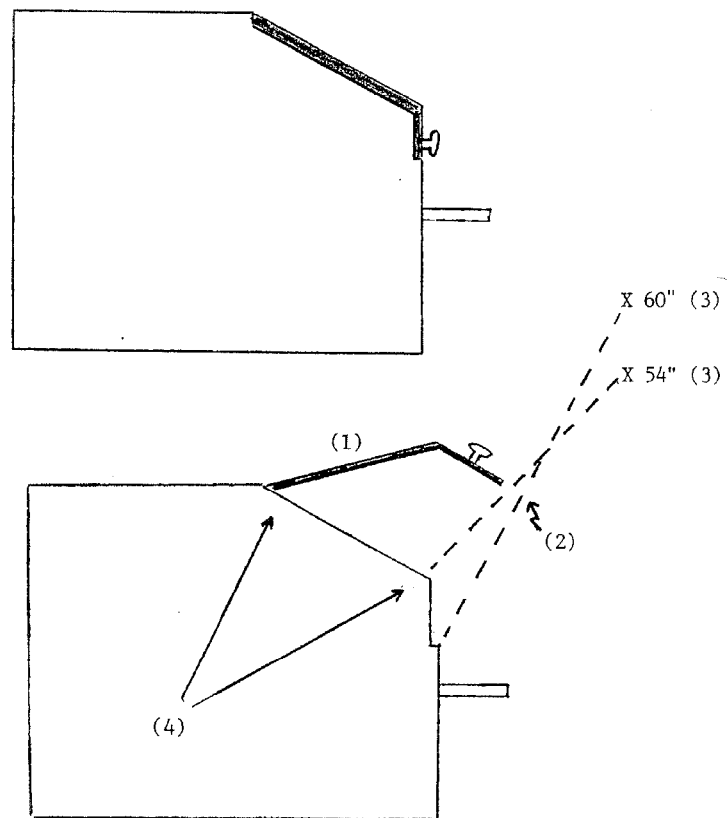

- (1) Securely attached tight-fitting lid with restricted range of opening. Lid functions as a sneeze-guard.
- (2) Point of maximum lid opening.
- (3) Average customer mouth height 54" to 60" above floor.
- (4) Opening into food container.

Equipment Approved for Self-Service Soda Dispensers

Section 114065 of California Retail Food Code requires that food be protected from contamination while being served. The self-service beverage dispensing equipment or mechanism and filling device of consumer self-service beverage dispensing equipment shall be designed to prevent contact with the lip-contact surface of glasses or cups that are to be refilled.

Two methods of sanitary self-service dispensing of soda have been approved and found to be in full compliance with the requirements of California Retail Food Code.

Push Button Type

The customer places the container under a nozzle and presses a button to dispense product. The container does not contact the dispenser in the “lip contact surface” during the filling

Approved Lever Type

The customer places the container under a nozzle and pushes a specially designed lever behind the nozzle with the container to begin dispensing. The lever is designed to extend down the length of the container, coming in contact with a spot well below the “lip contact surface”

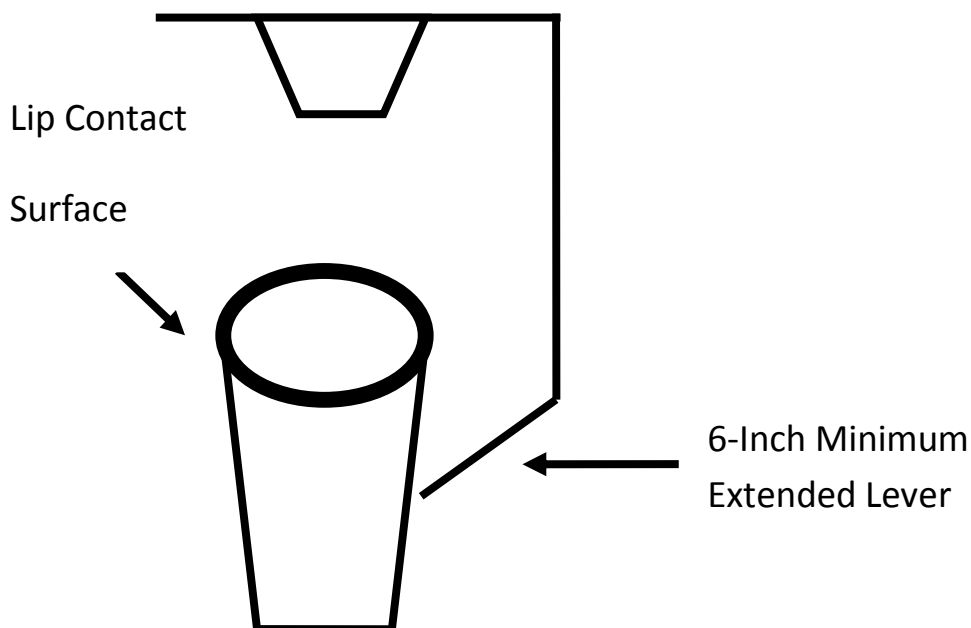

Section 5

Sinks

Food Preparation Sink

Utensil Washing Sink

Handwashing Sink

Dishmachines

General

High-Temperature Dishwashing Machines

Indirect Waste Drainage

Indirect Connection – Floor Sink

Indirect Connection – Funnel Drain

Side View Indirect Connection – Funnel Drain

Dipper Wells

Waste Disposal

General

Interior Refuse Disposal Rooms

Exterior Refuse Disposal Areas

Refuse Can Washing

Water Supply and Sewage Disposal

SINKS

Food Preparation Sink

A separate stainless steel sink must be provided in establishments where food preparation occurs or could occur (e.g., washing or trimming produce, soaking food, washing meat, thawing food under running water, etc.). The sink must have at least one compartment and either an integral stainless steel drainboard or be part of an integral stainless steel worktable. This sink is to be situated in a manner protected from potential sources of cross-contamination. For example, the food preparation sink must not be located next to the janitorial sink unless separated by an approved waterproof partition. Other requirements include:

- Food preparation sinks must drain to the sanitary sewer via an indirect waste receptacle (i.e., floor sink or funnel drain).
- When a food preparation sink is installed next to a wall, a stainless steel, FRP, or ceramic tile backsplash, extending up the wall at least 8-inches, is to be provided if not an integral part of the sink.
- Additional food preparation sinks may be required depending on the type of operation. For example, the use of different food preparation sinks may be required for produce and raw meat items; a separate food preparation sink just for raw seafood is required in a sushi bar.
- Separate areas within a large facility are required to have their own food preparation sink(s).
- Preparing meat or produce items “off-site” does not preclude the requirement for a food preparation sink if these items are handled at a facility.
- Food preparation sinks are not to be used for handwashing, utensil washing, the disposal of mop water or other wastes, or any other unapproved purpose.
- A minimum of 18”x 18” x 12” deep with an integral drain board or adjacent table at least 18”x18” in length and width.

Utensil Washing Sink

The proper washing of utensils consists of a three-step process. After scraping off food debris, the utensils are cleaned in warm, soapy water; then rinsed clean of soap; and finally, the utensils are sanitized by soaking in warm sanitizer solution. After the sanitizing step, the utensils are then air-dried. Where any utensils are used (e.g., customer multi-use, kitchen, serving, beverage machine heads or taps, etc.) a stainless steel 3-compartment sink with dual integral drainboards is required. Each sink compartment accommodates one of the washing steps described above. Even facilities that only make coffee (coffee pot) or sell unpackaged jerky (serving tongs) or make ice (scoop) have utensils that need to be regularly washed in a sanitary manner. In these establishments, a 3-compartment sink is also required. Please note that plastic NSF-listed utensil sinks are not allowed. Other requirements include:

- For most establishments, the minimum size of each compartment is to be at least 17-inches x 17-inches x 12-inches deep; however, the sink and drainboards must be sized to accommodate the largest utensil in use at the facility.

- The minimum size of a compartment in a bar sink is 10-inches x 14-inches x 10-inches deep with minimum 18-inch long drainboards. Plastic bar sinks are not allowed.
- For facilities using equipment intended to be cleaned in place, a detailed plan for the proper cleaning of this equipment must be provided for EHD review and approval.
- Utensil sinks must drain to the sanitary sewer via an indirect waste receptacle (i.e., floor sink or funnel drain).
- When a utensil sink is installed next to a wall, a stainless steel, FRP, or ceramic tile backsplash, extending up the wall at least 8-inches, is to be provided if not an integral part of the sink.
- Each compartment is to be provided with hot and cold water via a premixing faucet. The faucet must be long enough to reach each compartment.
- A bar sink may require a fourth compartment or “quick” funnel drain for the disposal of ice waste.
- Each drainboard is to be at least as big as the largest sink compartment.
- Separate areas within a large facility may be required to have their own 3-compartment utensil sink(s).
- Utensil washing sinks are not to be used for handwashing, food preparation, the disposal of mop water or other wastes, or any other unapproved purpose.

Handwashing Sink

Proper handwashing is a critical component of safe food handling. Improper handwashing is one of the leading causes of food-borne illness outbreaks. Select sink locations that encourage handwashing by being readily accessible and conveniently located. The ability of customers to witness handwashing (e.g., in front areas) can promote a positive sanitation image for a facility. You can never have too many handwashing sinks. Other requirements include:

- Handwashing sinks (lavatory) must be provided in each area where food is handled or prepared, and in each utensil washing area. They must be sufficient in number and conveniently located so as to readily facilitate handwashing. Depending on the size and layout, some rooms or areas may need multiple handwashing sinks to realistically encourage good handwashing habits. As a general rule handwashing sinks should be no more than 15-20 feet travel distance from a workstation in the same room or area.
- Soap and sanitary towels must be provided in permanently installed, enclosed, single-service dispensers located by each handwashing sink.
- Separate handwashing sinks must be installed within each area where food is prepared (e.g., deli, meat department, bakery, etc.) and each satellite area of a restaurant (e.g., sushi bar, oyster bar, bar, serving line, wait station, utensil washing, etc.).
- When a handwashing sink is installed next to a wall, a stainless steel, FRP, or ceramic tile backsplash extending up the wall at least 8 inches is to be provided if not an integral part of the sink.
- Each sink is to be provided with hot and cold water via a pre-mixing faucet.
- Handwashing sinks installed less than one foot from food preparation or storage areas must be separated by an approved partition at least 6-inches in height.
- Handwashing sinks are not to be used for utensil washing, food preparation, the disposal of mop water or other wastes, or any other unapproved purpose.

DISHMACHINES

General

The following are general requirements for dishmachines:

- Dishmachines must be provided with thermometers and pressure gauges to indicate the temperature and water pressures of the wash, rinse, and sanitizing cycles if these have operating ranges specified by the manufacturer or listing agency.
- Dishmachines that use the water supply pressure for the final rinse must have a pressure regulator.
- Dishmachines with an “internal or built-in air-gap” may be directly connected to the sewer immediately downstream from a floor sink or floor drain, or they may be drained to an approved indirect waste receptacle (i.e., floor sink or funnel drain).
- Machines that are designed for a chemical sanitizer (e.g., chlorine rinse) must be capable of maintaining the rinse at the temperature and sanitizer level specified by the manufacturer. Dishmachines using chlorine sanitizer must be able to maintain a level of free chlorine of at least 100 ppm in the sanitizer solution or the level specified by the manufacturer, whichever level is greater.
- Machines are to have two integral stainless steel drainboards or dish tables, one for clean utensils and one for dirty utensils. These are to be sloped & drained to an approved waste receptor. For under-counter dishmachines, there must be two comparable stainless steel drainboards adjacent to the machines (the drainboards of an adjacent utensil sink may be used).
- Under-counter dishmachines must be placed on 6-inch legs. Casters with flexible plumbing and electrical connections may be considered for approval if the unit is readily movable by one person. Plastic skids are not an acceptable substitute for legs or casters.
- Drainboards must be large enough to adequately store all utensils above the floor at all times or additional approved shelving, racks, or dish tables must be provided in the dishmachine area for this purpose. Drainboards must be of adequate size, design, and location so that clean and soiled utensils are kept segregated. Typically each drainboard should be large enough to accommodate two 20-inch dishracks.
- Garbage disposals may be installed in drainboards if installed in the “dirty” utensil drainboard and the drainboard is large enough to accommodate the disposal cone in addition to the minimum drainboard size. Garbage disposals may not be installed under a required sink compartment.
- A 3-compartment sink with its own dual integral drainboards is also required in addition to any dishmachine. A sink drainboard cannot be shared with a dishmachine drainboard. Shared drainboards may be considered on a case-by-case basis if additional space, such as stainless steel dishracks, dish tables, or slant shelves, is provided immediately adjacent to the dishwashing area.
- Water supply and waste lines must be adequately sized and consistent with manufacturer’s specifications.
- A pre-rinse unit or pre-rinse sink is required. It may be possible in some cases to use the utensil sink as the pre-rinse sink.

- Dishmachines must operate within the parameters specified by the manufacturer or listing agency, including water pressure and water temperature. A data plate containing these parameters must be permanently affixed to the unit by the manufacturer.

High-temperature Dishwashing Machines

Dishmachines that are designed for a hot water sanitizing rinse must be provided with a booster heater that is capable of maintaining a minimum final rinse water temperature of 180°F **at the manifold**. The machines (except for under counter units) must be provided with mechanical ventilation and make-up air. Except for conveyor-type dishmachines provided with approved eyebrow hoods, hoods over these units must extend at least 12-inches beyond the edge of the machine so that opening the doors will not release steam or vapors into the facility.

INDIRECT WASTE DRAINAGE

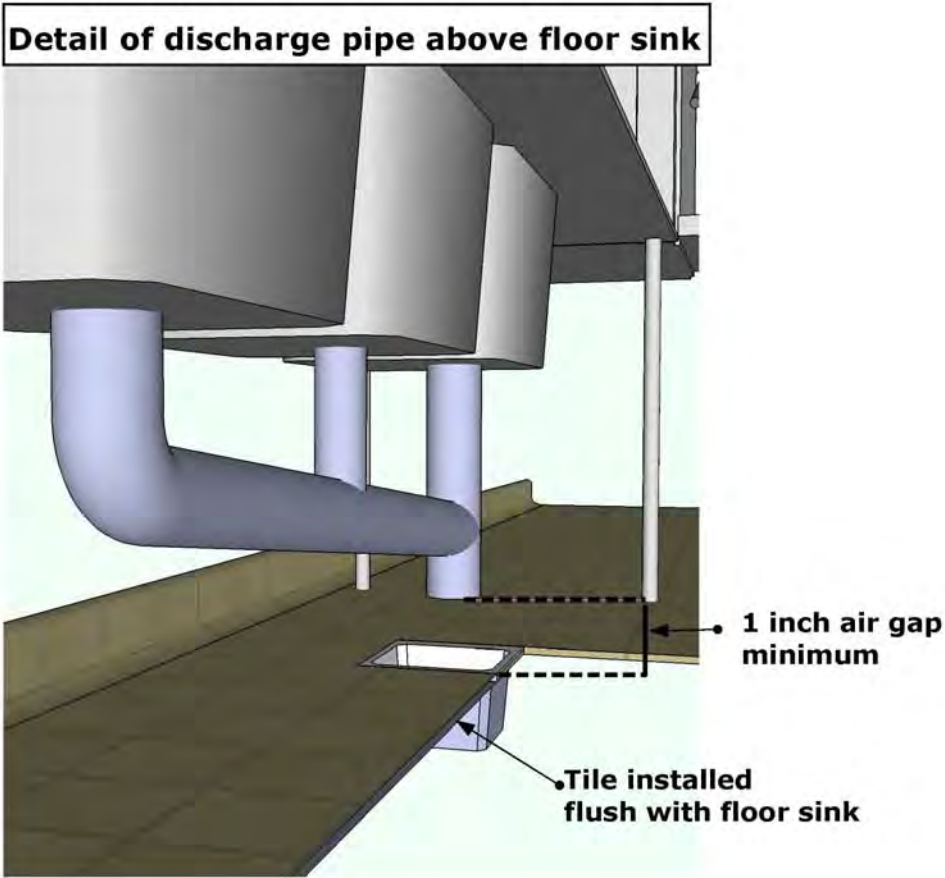
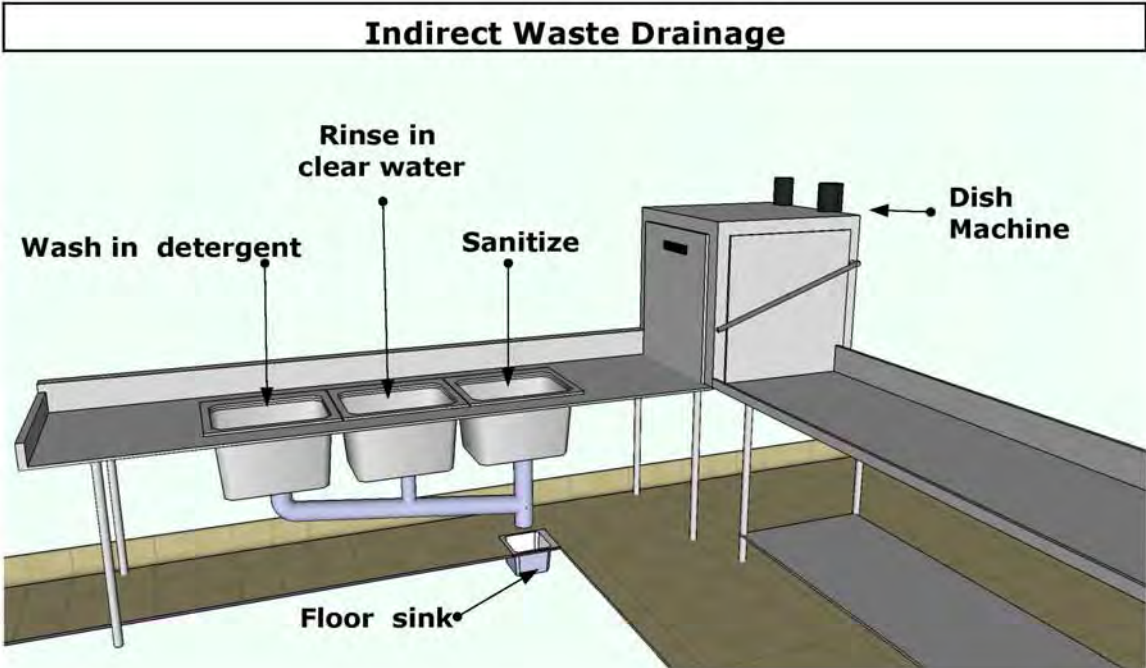

Front view of funnel drain installation for a 3-compartment sink

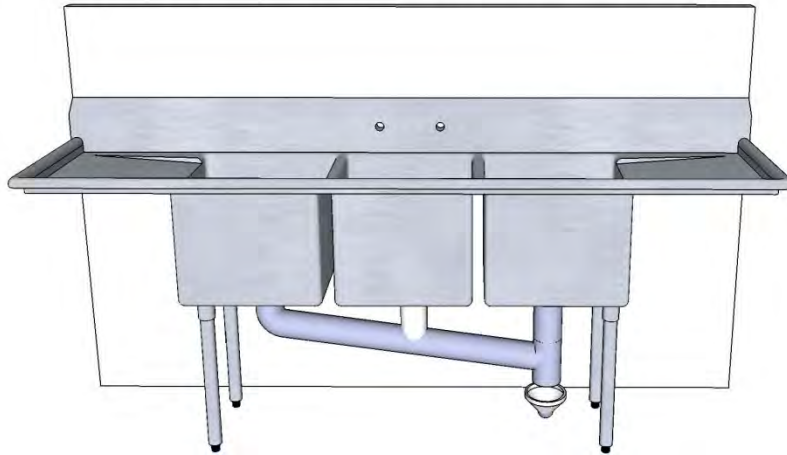

Side view of an indirect connection using a funnel drain

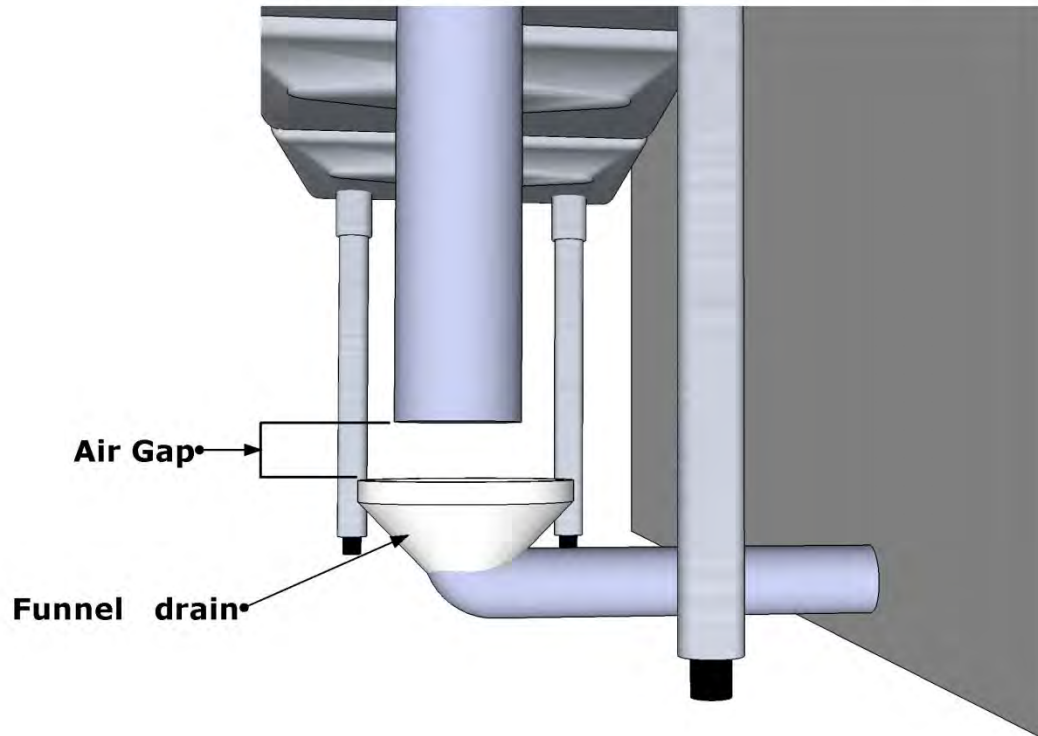

To prevent sewage contamination, condensate and liquid waste from food preparation equipment and sinks, utensil sinks, dishwashers, dipper wells, drainable steam tables, ice machines, beverage machines, refrigeration condensers, and similar equipment must be drained by readily accessible indirect drainage into a floor sink or funnel drain. Other requirements include:

- Unless otherwise required by the local building department, floor sinks must be installed flush with the floor surface. If raised above the floor, a smooth, easily cleanable, continuous coved base must be provided around the floor sink, extending integrally from the floor up to the lip of the sink with a minimum 3/8-inch radius at the floor sink/floor juncture. Seamless poured epoxy floor material (not paint) may be used for this purpose.
- Runs of piping outside of walls, floor, and ceilings must comply with the section addressing conduit and piping.
- Floor sinks and funnel drains must be located so that they are readily accessible for inspection and cleaning. When located under equipment, they must be located under the front edge or accessible side edge of the equipment (e.g., half-exposed). The minimum distance between the floor sink and overlying equipment is to be at least 8-inches. Readily accessible means direct access without the need to move equipment or remove a panel, door, or similar obstruction.
- Overflow from indirect waste receptacles must be prevented from flowing into inaccessible areas (e.g., cabinets, under display cases, etc.).
- “Cut-outs” may be allowed for indirect waste receptacles if the “cut-out” is at the front or accessible side edge, and separated (walled off) from the rest of the counter/cabinet, and the toekick surrounding the waste receptacle is integrally coved in an approved manner.
- Floor sinks located in traffic areas must be covered with an approved grate.
- Floor drains are not to be used in lieu of floor sinks.
- Discharge pipes must terminate at least one inch above the rim of the indirect waste receptacle (air gap).
- Contact the local building department regarding the location of indirect waste receptacles in relation to grease traps or grease interceptors.
- Check with the local building departments, some do not allow the use of funnel drains. (Funnel drains will only be allowed if a floor sink is impossible to install.)
- Pumps may not be used for condensate or other indirect waste drainage.

Dipper Wells

A cold running water dipper well must be provided if scoops or other utensils are used for serving potentially hazardous food (e.g., ice cream, rice, mashed potatoes, beans, etc.), and the utensil will be intermittently stored in water or at room temperature without cleaning and sanitizing between each use. Dipper wells must be installed near where the utensil will be used. Dipper wells must drain to the sanitary sewer via a readily accessible indirect waste receptacle (i.e., floor sink or funnel drain). The dipper well faucet must terminate at least one inch above the rim of the dipper well.

WASTE DISPOSAL

General

General requirements for waste disposal include:

- An area must be provided for storage of all anticipated wastes (e.g., garbage, rubbish, cardboard, grease cast off materials). The area is to have finishes comparable to food preparation areas (e.g., smooth, durable and easily cleanable).
- Outside trash storage areas are to be located as far as possible from delivery and customer-entry doors.
- Adequate watertight, nonabsorbent, rodent-proof containers with tight-fitting lids are to be provided for garbage disposal.

Interior Refuse Disposal Rooms

Requirements for interior refuse disposal areas include:

- Floors are to be smooth, durable, grease-resistant, nonabsorbent, coved, easily cleanable, and sloped to a floor drain. The drain must discharge to the sanitary sewer.
- Walls and ceiling are to be durable, easily cleanable, impervious to grease and moisture, and capable of withstanding impacts.
- This area is to be well ventilated.
- A hot and cold running water supply is to be provided through a pre-mixing valve or combination faucet protected against backflow.
- A drain to the sanitary sewer must be provided.

Exterior Refuse Disposal Areas

Floor and other surfaces within an exterior refuse disposal area must be durable and easily cleanable. For newly constructed exterior disposal areas or existing disposal areas serving a food facility for the first time, a hot and cold water supply and drain to the sanitary sewer is required unless prohibited by the local sewer authority. Covered trash enclosures may also be required by the local sewer authority.

Note: No waste of any kind may discharge to the ground surface or stormwater drainage system.

Refuse Can Washing

A suitable facility for washing garbage cans or other refuse containers is required if these types of containers are cleaned on site.

WATER SUPPLY AND SEWAGE DISPOSAL

All liquid waste must be discharged to a public sewer system or an approved septic system. Liquid waste drainage to the sewer system or septic tank must be gravity; pumps for this use are not allowed. An approved, adequate, protected, pressurized, potable supply of hot and cold water is to be provided at all times.

Section 6

Janitorial Facilities

Backflow Prevention

Hot Water Supply

JANITORIAL FACILITIES

Each food establishment must be provided with at least one of the following to be used exclusively for general cleaning purposes and the disposal of mop bucket and other cleaning waste:

- One-compartment nonporous janitorial sink.
- A curbed area (basin) that is properly sloped to a drain. All curbed surfaces are to be of smooth, durable, nonporous, and easily cleanable construction. Where rubber floor mats are used a curbed janitorial area is required. Other requirements include:
- Janitorial sinks or curbed areas must be supplied with hot and cold running water through a pre-mixing faucet. An approved method of backflow prevention is required on the faucet (atmospheric vacuum breaker).
- Janitorial facilities must be large enough to accommodate all cleaning supplies and equipment. These items are to be stored here and not in restrooms, food storage or preparation areas, utensil washing or storage areas, or employee change/storage areas.
- Janitorial facilities must be separate from food and utensil areas. If a janitorial sink or curbed area is located in a food or utensil area, it must be separated by an approved moisture-resistant partition (or wall) at least 5 feet in height.
- Establishments washing floor mats must have facilities to clean the mats and drain the wastewater to the sanitary sewer system.
- Janitorial sinks or curbed areas are not to be used for handwashing, utensil washing, food preparation, or any other unapproved purpose.
- Warehouses where ceilings are greater than 10 feet will not require a ceiling over the janitorial room.

Due to the characteristic use of janitorial facilities, it is recommended that care be given to providing well-ventilated areas and selecting extremely durable finish materials for the floor and walls. These should be chosen to withstand repeated moisture and impacts, in addition to being easily cleanable.

BACKFLOW PREVENTION

General requirements for backflow prevention include:

- An approved backflow prevention device is to be provided upstream of any potential hazard to the potable water supply. This includes threaded water outlets, hose bibs, janitorial sinks, dishwashers, sprayers, etc.
- Chemical feeders connected to the potable water supply must be protected against backflow and back-siphonage.

HOT WATER SUPPLY

A water heater must be provided, capable of consistently supplying hot water (at least 120°F) to all sinks, lavatories, dishwashing machines, etc. In sizing the heater, the peak hour demands for all fixtures are added together to determine the minimum recovery rate necessary. For situations where the water heater is located more than 60 feet from a fixture to be served, a re-circulating pump must be provided to insure that water of adequate temperature can be rapidly provided (on demand). Other requirements include:

- Use the ***Calculating Hot Water Demand*** check sheet for sizing water heaters.
- Electric water heaters with more than one heating element must be sized based on the use of simultaneous heating elements.
- When multiple water heaters are connected, they must be connected in parallel, not in series.
- A minimum 10-gallon water heater is required for establishments' handling/selling only prepackaged food items.
- If located inside the establishment, the water heater must be placed on approved legs at least 6-inches high or a minimum 4-inch high integrally coved platform.
- The water heater must be capable of heating water to 140°F if a high temperature dishmachine with a 40°F booster heater is used.
- Shared water heaters are not allowed.

Section 7

Doors

Delivery Doors

Customer Entry Doors

Windows

General

Pass-Through Windows Standards

Lighting

General Requirements

Shatter-Proof Covers

Signs

DOORS

General

Exterior doors must be self-closing (except for large cargo doors used exclusively for delivery) and well fitted to prevent the entrance of insects and vermin. A guide to use for preventing rodent entry is the elimination of gaps large enough to accommodate a pencil thickness.

Delivery Doors

Delivery doors must open outward. They must be provided with an overhead air curtain or when required by EHD to exclude insects. The air curtain must provide a downward-outward flow not less than 8-inches wide at the nozzle and an airflow not less than 1600 feet per minute across the entire opening at a point measured 3 feet above the floor. The air curtain must turn on automatically when the door is opened.

Large cargo-type doors must not open directly into a food preparation area. Cargo-type doors that open into a food warehouse may only be open during deliveries. An air curtain is not meant to allow doors to remain open when the doors are not in use.

Customer Entry Doors

Entrance doors leading to the outside should open outward and must be self-closing.

WINDOWS

General

All windows must be tight fitting. Openable windows must be covered with 16 or finer mesh screen.

Pass-through Windows

Pass-through windows may be allowed if the facility is not subject to excessive dust or flies. When food is passed through a window to a customer on the outside of the building, the size of the window may not exceed 432-square inches. The minimum distance between multiple windows is to be at least 18-inches.

Counter surfaces of the pass-through window must be smooth, free of channels or crevices and be easily cleanable.

If an air curtain is used, it must produce at least an 8-inch wide airflow across the entire window opening, with an air velocity of at least 600 feet per minute (as measured 3 feet below the air curtain). Window openings must be kept closed when not passing items through.

(Pass-through window service openings shall be limited to 216-square inches each. The service openings shall not be closer together than 18 inches. Each opening shall be provided with a solid or screened window, equipped with a self-closing device. Screening shall be at least 16 mesh per square

inch. Pass-through windows of up to 432-square inches are approved if equipped with an air curtain device. The counter surface of the service openings shall be smooth and easily cleanable.)

LIGHTING

General Requirements

Light of at least 20 foot-candle (ftc) intensity must be provided during hours of operation in the kitchen, other food handling areas, customer self-serve areas, restrooms, utensil washing and storage areas, and inside reach-in and under-counter refrigeration units. Light of at least 50 ftc intensity must be provided in areas where employees use knives, grinders, slicers, saws, or similar type equipment, and in all areas during cleaning operations. Other areas (including walk-in refrigerator and freezer units) may operate with a light intensity of at least 10 ftc, except during cleaning activities when at least 20 ftc intensity must be provided. Essentially, the ability to provide at least 20 ftc intensity must be provided throughout the facility except as otherwise specified.

Shatter-proof Covers

Shatter-proof light-covers are to be provided in areas where food is prepared, stored (except those areas used exclusively for the storage of food in the original unopened containers).

SIGNS

Food establishments are required to maintain the following signage:

- *Hand-washing*: Signs directing employees to wash their hands must be posted in restrooms and at all other handwashing sinks.
- *No Smoking*: Must be placed in food preparation, food storage, and utensil cleaning and utensil storage areas.
- Other signs as necessary for food safety and sanitation.
- Sign informing the customer that the most recent inspection report is available on-site for review.

If a facility has sit-down dining, it is recommended to post a choking first aid sign in a location readily accessible to employees.

Section 8

Shelving

Storage

General

Calculating Storage Space Needs

Restrooms

Employee Change / Storage Areas

SHELVING

General requirements for shelving include:

- All shelving must be commercial-grade metal, plastic, or fully plastic-laminated. Varnished or painted wood is not approved in food processing.
- In warehouses where food is stored in large unopened bulk shipping containers, pallets for such items may be approved by EHD if a functional forklift or pallet jack is kept on site and the floor underneath and around the pallets is kept clean.
- Shelves installed on a wall must have at least one inch of open space between the back edge of the shelf and the wall, or the back edge of the shelf must be sealed to the wall with silicone sealant.
- The lowest shelf must be at least 6-inches above the floor with a clear unobstructed area below.
- All shelves located below a counter top or work area must be set back at least 2-inches from the drip line of the surface above.
- Inspectors may require shelving used only for the display of prepackaged food items to comply with these requirements if sanitation problems are observed or anticipated.

STORAGE

General

The lack of adequate storage or improperly designed or located storage is a major cause of sanitation problems in food establishments. Storage design must facilitate cleaning operations, eliminate vermin/insect harborage, and prevent interference with food facility operations. Particular care must be taken to assure that adequate storage space is provided.

Adequate and suitable space must be provided for the storage of food, beverages, utensils, linens, etc. In addition to working storage and refrigerator/freezer storage, additional backup storage must be provided. In calculating backup storage, only aisle space and floor area where shelving, cabinets or other storage facilities are located will be considered. Floor area where desks, ladders, or where other items not storage related may be placed, are not to be used in calculating storage area. Working storage includes cabinets or shelves over or underneath food handling/preparation areas. Other requirements include:

- Adequate and suitable space, separate from food and utensils, is to be provided for the storage of soiled and clean linens.
- A room, area, shelving, or cabinet separated from food preparation, food storage, utensil washing and utensil storage areas is to be provided for storing all cleaning equipment, cleaning supplies, and poisonous substances. Typically, the janitorial sink area is a good location to store these items.
- If located in a food preparation area, poisonous substances are to be stored in a separate approved enclosure (e.g., cabinet).

- All food, except those stored in the original large unopened bulk containers are to be stored at least 6-inches above the floor. Large containers of bulk foods in original unopened containers may be stored on dollies or pallets less than 6-inches high if these are easily cleanable and readily movable—and a functional forklift or pallet jack is kept on site.
- Storage areas or rooms must open up into the establishment. “Remote” food or utensil storage outside of the establishment is not allowed.

Calculating Storage Space Needs

In addition to working storage and refrigerator/freezer storage, backup storage must be provided. General guidelines for calculating the minimum required storage:

- Provide backup storage shelving equivalent to 25% of all kitchen space or one square foot of shelving per customer seat, whichever is greater (minimum 144 square foot of approved shelving).
- Provide sufficient approved shelving dispersed throughout the kitchen or other storage area(s).
- Bars or bar areas must have at least 72 square feet of backup storage shelving.
- Establishments selling only prepackaged products must have an area or room at least 30 square feet in size, with at least 72 square feet of approved shelving.
- Each separate department in a supermarket or other large food establishment must have its own backup storage meeting these requirements.

These formulas are most applicable to smaller establishments. Larger facilities will require significantly more storage space.

RESTROOMS

Toilet facilities, convenient for use by employees, must be provided **within** the facility. Employees must be able to properly wash their hands before leaving the toilet facilities. The number of toilet facilities (including handicapped) is to be in accordance with local building and plumbing codes. Other requirements include:

- Customer toilet facilities must be located so customers do not have to pass through food preparation, food storage, or utensil washing areas.
- Handwashing sinks must be provided within or immediately adjacent to each toilet room. The lavatory must be provided with hot (120°F) and cold running water via a pre-mixing faucet or 100°F if the sink turns on automatically and the temperature cannot be adjusted. Soap and hand towels must be provided from permanently mounted enclosed, single-service dispensers. Toilet tissue is to be provided in permanently mounted, enclosed dispensers located at each toilet.
- Signs directing employees to wash their hands after using toilet facilities must be conspicuously posted.
- Restrooms are to be provided with tight-fitting, self-closing doors.

- Toilet rooms are to be provided with ventilation to outside air. If adequate ventilation cannot be provided by a screened window (openable) or airshaft, then mechanical ventilation that is integrally controlled by the light switch is to be provided.
- Public toilet facilities must be provided in each food establishment with more than 20,000 square feet of floor space. Separate men and women's toilet facilities must be provided in these facilities.
- Regardless of the size of the food establishment, public toilet facilities are required in all food establishments located in new buildings constructed after January 1, 2004, if food or beverage is consumed on the premises.
- A vestibule is required if an employee restroom opens up into an area where food is prepared or stored, or where utensils are washed or stored.
- Toilet rooms are not to be used for the storage of food, utensils, equipment, or employee belongings.

EMPLOYEE CHANGE/STORAGE AREAS

A room, enclosure, or designated area (at least 4 feet x 5 feet recommended) is to be provided where employees may change and store their outer garments and personal belongings. This could include lockers, shelves, coat hooks, or cabinets. A larger change room or an additional space may be required depending on the total number of employees. This area is to be separated from toilets, food storage, food preparation areas, utensil washing, utensil storage areas, and cleaning equipment/supply storage areas. Such rooms, areas, or enclosures are to be used for no other purpose.

Where lockers are used, they must be on an integrally coved base (see floor section of this handout), wall-mounted at least 6-inches above the floor, or on approved minimum 6-inch high legs. If on legs less than 6-inches apart, no more than four lockers may be installed in a row.

Section 9

Miscellaneous

Enclosed Facility

Vermin Exclusion

Areas of Multiple Uses

Grease Traps and Grease Interceptors

MISCELLANEOUS

Enclosed Facility

Food establishments must be fully enclosed. Walk-in refrigeration and freezer units, storage areas, must open directly into the establishment. Outside areas used exclusively for dining are allowed if separated from an enclosed facility.

Vermin Exclusion

Since rodents and insects can spread many diseases by contaminating food or utensils, particular care must be taken to exclude vermin from a facility and eliminate areas that might provide harborage. Suitable equipment elevations, spacing conduit from walls, sealing conduit chases, full vermin-proof enclosure, well-organized storage, etc., all contribute to an integrated pest control program.

Approved flytraps must be located at least 3 feet horizontally from food, food handling areas, food equipment, or utensils. Flytraps that do not retain the insects are not allowed (i.e., no bug zapper-type units or fly paper).

Areas of Multiple Uses

The finishes in any area are to comply with requirements for the most stringent use intended. For example, a room used for utensil washing and the storage of unopened food containers would have to comply with the requirements applicable to utensil washing areas.

Grease Traps and Grease Interceptors

Contact the local building department or sewer agency for requirements as to the sizing, installation, and location of grease traps and grease interceptors. Grease traps and grease interceptors must be readily accessible for inspection and cleaning. When installed inside the building, the top of the grease trap must be flush with the surrounding floor and not pose a tripping hazard.

Note: When at all possible, grease traps or interceptors are recommended to be located somewhere outside the food facility and away from public traffic for easy access to pump and repair.

Section 10

Forms

Room Finish Schedule

Hood Worksheet

Hot Water Demand Worksheet

Hourly Hot Water Demand Table

Hot Water Demand for Tankless

Instantaneous Water Heaters

Plan Check Submittal Quick Checklist

Incidental Pre-Packaged Retail Food

Facility Quick Checklist

Floor Diagrams

ROOM FINISH SCHEDULE

ROOM OR AREA	FLOOR	FLOOR BASE (1) OR COVE	WALLS (2)	CEILING (2)	REMARKS

(1) Indicate if the floor material is to extend up walls and toekicks at least 4" with a minimum 3/8" radius at the wall/floor and toekick/floor juncture.

(2) Specify color(s).

HOOD WORKSHEET

FACILITY NAME:		
ADDRESS:		
PREPARED BY:	COMPANY:	DATE:

A: COOKING EQUIPMENT & HOOD: Fill in cooking equipment & hood dimensions in feet in overhead view.

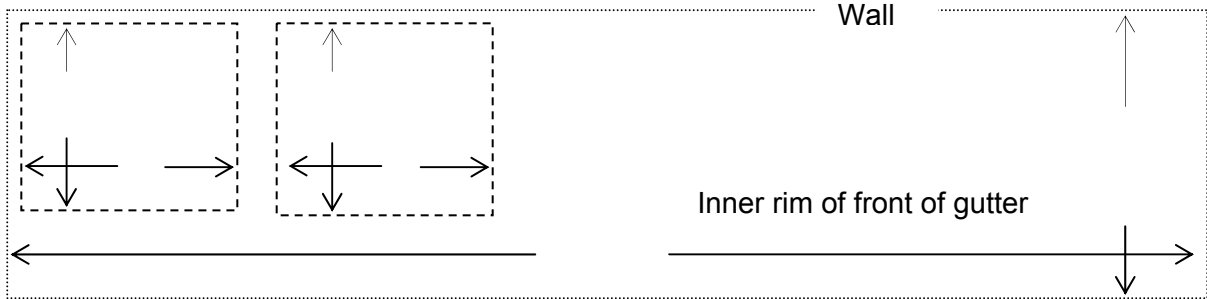

Casters & quick disconnects strongly recommended! Specified?	<input type="checkbox"/> Yes	<input type="checkbox"/> No
Hood long enough to allow $\geq 6"$ on sides of equipment?	<input type="checkbox"/> Yes	<input type="checkbox"/> No
Hood wide enough to allow $\geq 6"$ in front & back of equipment?	<input type="checkbox"/> Yes	<input type="checkbox"/> No
Canopy lip $\geq 6.5'$ above floor & $\leq 4'$ above cooking surface?	<input type="checkbox"/> Yes	<input type="checkbox"/> No
Canopy free of exposed horizontal electrical & Ansul lines?	<input type="checkbox"/> Yes	<input type="checkbox"/> No
Hood material; (e.g., stainless steel) (cannot be galvanized)	<input type="checkbox"/> Yes	<input type="checkbox"/> No

B: CFM

What kind of hood?	<input type="checkbox"/> Type I	<input type="checkbox"/> Type II	Make:	Model:
--------------------	---------------------------------	----------------------------------	-------	--------

Hood opening: _____ ft x _____ ft = _____ sq ft x _____ Q factor from CMC = _____ CFM
(length) (width)

Other formula? _____ = _____ CFM

C: FILTERS

_____ " H x _____ " W _____ x _____ sq ft = _____ sq ft
(Filter Size) (# of Filters) (usable area per filter) (total filter area)

_____ CFM \div _____ sq ft (total filter area) = _____ fpm

Baffle filter ideal fpm = 300; should be 250-350.	<input type="checkbox"/> Yes	<input type="checkbox"/> No	
Horizontal slot filter ideal fpm = 1000; should be 800-1200.	<input type="checkbox"/> Yes	<input type="checkbox"/> No	<input type="checkbox"/> NA
Fpm can be < or > above if this is a "LISTED" hood.	<input type="checkbox"/> Yes	<input type="checkbox"/> No	
Total of filter widths _____ must be < hood length.	<input type="checkbox"/> Yes	<input type="checkbox"/> No	

D: DUCT

Duct dimensions: _____" x _____" = _____" ÷ 144 = _____ sq ft

Hood >12 ft. long shows >1 exhaust outlet to main duct?	<input type="checkbox"/> Yes	<input type="checkbox"/> No	<input type="checkbox"/> NA
---	------------------------------	-----------------------------	-----------------------------

_____ CFM ÷ _____ sq ft = _____ fpm

Fpm must be no greater than 2500.	<input type="checkbox"/> Yes	<input type="checkbox"/> No	<input type="checkbox"/> NA
-----------------------------------	------------------------------	-----------------------------	-----------------------------

F: STATIC PRESSURE & EXHAUST FAN

No. of elbows:	Cleanout at each elbow?	<input type="checkbox"/> Yes	<input type="checkbox"/> No	<input type="checkbox"/> NA
Static Pressure (SP):				

Exhaust Fan	Make:	Model:	H.P:
-------------	-------	--------	------

UL 762 Restaurant Application specified for Type I?	<input type="checkbox"/> Yes	<input type="checkbox"/> No	Easily pulls CFM at SP?	<input type="checkbox"/> Yes	<input type="checkbox"/> No
---	------------------------------	-----------------------------	-------------------------	------------------------------	-----------------------------

G: FILTERED MAKE-UP AIR

_____ CFM ÷ 2000 CFM = _____
 (Exhaust) (max. per diffuser recommended)

Next higher whole number = _____ Diffusers recommended

Make-up air fan	Make:	Model:	H.P:
-----------------	-------	--------	------

Static Pressure (SP):	Supplies 95-100% of exhaust CFM at SP?	<input type="checkbox"/> Yes	<input type="checkbox"/> No
Make-up air on roof ≥ 10 ft. from exhaust?		<input type="checkbox"/> Yes	<input type="checkbox"/> No
Make up air diffusers ≥ from 10 ft. hood canopy?		<input type="checkbox"/> Yes	<input type="checkbox"/> No
Exhaust & make-up air interlocked?		<input type="checkbox"/> Yes	<input type="checkbox"/> No

HOT WATER DEMAND

FACILITY NAME:	
ADDRESS:	DATE:

Fixtures	No. Units	Length (in)	Width (in)	Length (ft)	Width (ft)	GPH	No. Compartments	equals	Total GPH
Utensil / 3-Compartment Sinks									
Mop Sinks									
Dump Sinks									
Outdoor Trash Area									
Hand Sinks									
Food Preparation Sinks									
Handspray / Pre-rinse Units									
Employee Shower									
Clothes Washer									
Automatic Utensil Washing Machine*									
Additional Utensil / 3-Compartment Sinks									
Total GPH (gallons per hour)									

Sizing Requirements for Storage Water Heaters (Not Instantaneous Water Heaters):

Facilities with multi-service eating utensils, heavy use (serving 3 meals a day)	100% GPH required
Facilities with multi-service eating utensils, moderated use	90% GPH required
Facilities with single service eating utensils or don't use utensils at all	80% GPH required

_____ Total GPH x _____ % (see sizing requirements above) _____ GPH required

Computing the BTU input (Gas Water Heaters):

_____ GPH required x 60° Rise x 11 = _____ BTU input of water heater

_____ GPH required x 80° Rise x 11 = _____ BTU input of water heater
 (if a 180° rinse automatic utensil washing machine with a 40° rise booster is used)

Formula for Electric Water Heaters:

_____ GPH required x (.149) = _____ KW input required
 (60° rise)

_____ GPH required x (.2) = _____ KW input
 (80° rise, if a 180° rinse automatic utensil washing machine with a 40° rise booster is used)

*NSF International or other nationally recognized testing laboratories are used to determine the minimum GPH hot water demand required for automatic utensil washing machines.

Hot Water Demand Calculator is available on www.co.merced.ca.us/eh.

HOURLY HOT WATER DEMAND TABLE

Utensil Sinks

- 18" x 18" 14 gallons per compartment
- 24" x 24" 25 gallons per compartment
- Others Calculate based on compartment use

Custom sink sizes can be calculated using the following formula:

$$\text{Length (ft.) X Width (ft.) X Depth (ft.) X 7.5 = gallons per compartment}$$

Bar Sinks

6 gallons per compartment

Hand Sinks

5 gallons per sink

Dishwashing Pre-rinse Units

- Hand spray type 45 gallons
- Others refer to manufacturer's specifications

Dishwashers

refer to manufacturer's specifications

Food Preparation Sinks

5 gallons per sink

Clothes Washers

- 9 – 12 lb. washers 45 gallons
- 16 lb. washers 60 gallons
- Others refer to manufacturer's specifications

Employee Shower

20 gallons per shower

Janitorial Sinks / Garbage Can Wash Facilities

15 gallons per sink

Other Fixtures

refer to manufacturer's specifications

For additional information on sizing and installation of water heaters see Guidelines for Sizing Water Heaters available on the CCDEH website: http://www.ccdeh.com/document/cat_view/87-food-safety-guidelines?start=30

HOT WATER DEMAND FOR TANKLESS / INSTANTANEOUS WATER HEATERS

FACILITY NAME:	
ADDRESS:	DATE:

FIXTURE SERVED	NO. UNITS		GPM		TOTAL GPM
Utensil / 3-Compartment Sinks		X	2	=	
Mop Sinks		X	2	=	
Outdoor Trash Area		X	2	=	
Hand Sinks		X	0.5	=	
Food Preparation Sinks		X	0.5	=	
Handspray / Pre-rinse Units		X	2	=	
Employee Shower		X	2	=	
Clothes Washer		X	2	=	
Automatic Utensil Washing Machine*		X		=	
TOTAL GPM (gallons per minute)				=	
TOTAL GPH (gallons per hour) (Total GPM x 60)				=	

Computing the BTU input (Gas Water Heaters):

_____ GPH required x 60° Rise x 11 = _____ BTU input of water heater

_____ GPH required x 80° Rise x 11 = _____ BTU input of water heater
 (if a 180° rinse automatic utensil washing machine with a 40° rise booster is used)

Formula for Electric Water Heaters:

_____ GPH required x (.149) = _____ KW input required
 (60° rise)

_____ GPH required x (.2) = _____ KW input
 (80° rise, if a 180° rinse automatic utensil washing machine with a 40° rise booster is used)

*NSF International or other nationally recognized testing laboratories are used to determine the minimum GPM hot water demand required for automatic utensil washing machines.

Hot Water Demand for Tankless / Instantaneous Water Heaters Calculator is available on www.co.merced.ca.us/eh.

Plan Check Submittal Quick Checklist

Below are some common items, which are typically missing or inadequately detailed that may delay plan review and approval. This checklist is not all inclusive and is subject to change without notice. Refer to the appropriate state laws and CCDEH construction guidelines for additional requirements and details. We provide pre-design consultation on an appointment basis. Please contact our office at 209-381-1100 between 8:00am and 5:00pm to make an appointment.

Yes Sheet #	N/A	Plan Layout	Guide Pg#
		one (1) complete set of plans (accurate, clear, drawn to scale, 1/4" per 1' recommended, and must be designated for construction only).	2
		Clearly designate/describe all areas, including kitchens, storerooms, bars, wait-stations, customer self-serve stations, garbage/refuse storage, utensil washing, display floors, employee locker areas, chemical storage, janitorial, and offices.	2
Yes Sheet #	N/A	Finishes	Guide Pg#
		Finish Schedule: Wall and ceiling finishes and materials described for each area, including walk-in units and restrooms.	4, 11
		Finish Samples: Floor, wall and ceiling samples provided (including integral cove bases). <i>(Note: Foot of cove pieces must be at least 1/4" long.)</i> Provide scale cross-section drawings of all integral cove bases (including at counter toekicks).	4
Yes Sheet #	N/A	Equipment	Guide Pg#
		Equipment cut-sheets/manufacturer specification sheets for all equipment showing conformance with applicable NSF standards. Number cut-sheets/manufacturer specification sheets to correspond with equipment numbers designated on plans.	14
		Clearly show locations of all equipment.	2
		For unlisted equipment, sufficient details to determine ANSI/NSF equivalency.	14
		Elevations for all equipment (e.g., 6" legs, casters, cove base). Do not show casters less than 6" high unless equipment can be readily moved.	14
		Food preparation sink required (except in prepackaged food only facilities). For a typical retail food facility, you would need a utensil (three compartment sinks), food preparation, mop/janitorial and handwashing sinks.	28
Yes Sheet #	N/A	Lighting	Guide Pg#
		Submit lighting plan. Light of at least 20 foot candles (ftc) intensity must be provided during hours of operation in the kitchen, other food handling areas, customer self-serve areas, restrooms, utensil washing and storage areas, and inside reach in and undercounter refrigeration units. Light of at least 50 ftc intensity must be provided in areas where employees use knives, grinders, slicers, saws, or similar type equipment, and in all areas during cleaning operations.	39
		Shatter-proof covers or bulbs indicated where required.	39
Yes Sheet #	N/A	Water Heater	Guide Pg#
		Water heater size, location, recover rate (BTU's or kilowatts), and if floor mounted, approved installation (e.g., 6" legs). Provide cut sheet.	37
		Hot water demand calculation. See handout Hot Water Demand Worksheet.	Sect. 10
Yes Sheet #	N/A	Trash Enclosure or Area	Guide Pg#
		Location and construction shown of trash areas. Easily cleanable and durable floors, walls, and ceilings.	35
		Show drainage and hot/cold plumbing details. Must be approved potable water.	35
		Water heater minimum 10 gallon tank with 2.24 kw (show location, cut sheet if tankless minimum 17.88 kw,	37

		or 79,200 BTU's)	
		Drain to sanitary sewer.	35
Yes Sheet #	N/A	Ventilation	Guide Pg#
		Hood details and completed hood worksheet for cooking equipment and non-undercounter high-temperature dishwashing machines. See Plan Check Guideline.	Sect. 10
		UL placard or equal for UL or equal listed hoods. Documentations is subject to verification and must include the model specific UL criteria, including exhaust volume, filter airflow rates, hood overhang (which may be greater than UMC), make-up air, duct details, and any equipment or other limitations.	17
		Submit room ventilated plans. Restrooms provided with ventilation.	
		Six inch or more hood overhang, depending on equipment installed. Note: Ductless hoods, short circulating hood systems, or other unapproved types will not be approved	
Yes Sheet #	N/A	Storage	Guide Pg#
		Provide backup food/beverage storage shelving equivalent to 25% of all kitchen space or one square foot of floor shelving per customer seat, whichever is greater (minimum 144 square feet of approved shelving).	40
		Provide sufficient approved shelving dispersed throughout the kitchen or other storage area(s).	40
		Bars or bar areas must have at least 72 square feet of backup storage shelving.	
		Each separate department in a supermarket or other large food establishments must have its own backup storage meeting these requirements.	40
		Provide adequate storage facilities for non food items (e.g., utensils, dishes, paper products, and linens.) Note: Establishments selling only prepackaged products must have an area or room at least 30 square feet in size, with at least 72 square feet of approved shelving.	40
Yes Sheet #	N/A	Plumbing/Indirect Waste	Guide Pg#
		Submit plumbing plans.	
		Indirect waste receptacles with minimum 1" air gap (floorsinks/funnel drains) shown for utensil sinks, prep sinks, walk-in condensers, beverage units, ice machines, etc.	34
		Indirect waste receptacles readily accessible for inspection and cleaning.	34
		Location of all floor drains. Traffic areas slope to floor drains where installed. Note: Floor drain required in kitchens with Type I hood systems, utensil washing areas, meat or fish handling areas, produce trimming areas, bars.	
		Hot and cold water with pre-mixing faucet provided to each sink. Faucet sprout reaches each sink compartment of multi-compartment sinks.	
		Handsink(s) in each food and/or beverage handling area and utensil washing area.	
Yes Sheet #	N/A	Janitorial Facilities	Guide Pg#
		Mop sink or basin must be installed to prevent contamination of food, food preparations surfaces, utensils or equipment. Large enough to wash floor mats if these are used at the facility. Provide cut sheet. Note: Hot and cold running water through pre-mixing faucet and approved back flow prevention.	
Yes Sheet #	N/A	Vermin Control	Guide Pg#
		Exterior hinged doors self-closing.	
		Delivery doors protected by approved automatically activated air curtain.	
		Openable windows screened (minimum 16 mesh).	
		No gaps, holes, harborage, or entryways for vermin (including underneath doors).	
Yes Sheet #	N/A	Grease Traps/Interceptors	Guide Pg#
		Show location.	2
		Must be accessible for inspection and cleaning. Note: Shall not be located in food handling and/or utensil washing areas.	43

Yes Sheet #	N/A	Miscellaneous	Guide Pg#
		Any facility on septic system or well must be approved by the Land Use program.	

For a complete description of applicable requirements, please refer to Environmental Health Division Construction Guide for Retail Food Facilities. You can download a copy at www.countyofmerced.com/eh or call (209)381-1100.

EXAMPLES OF FLOORING INSTALLATION

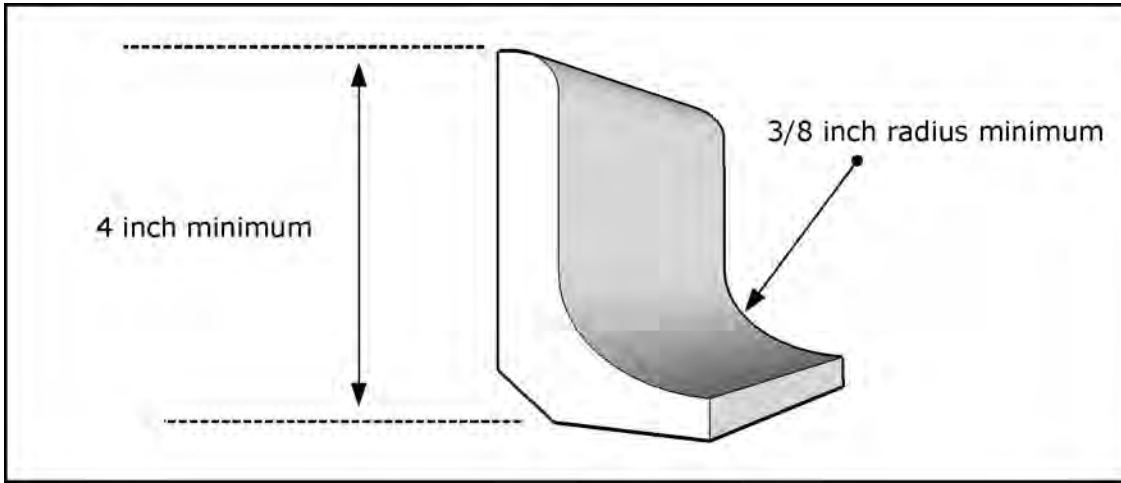

Quarry Tile
Cove base

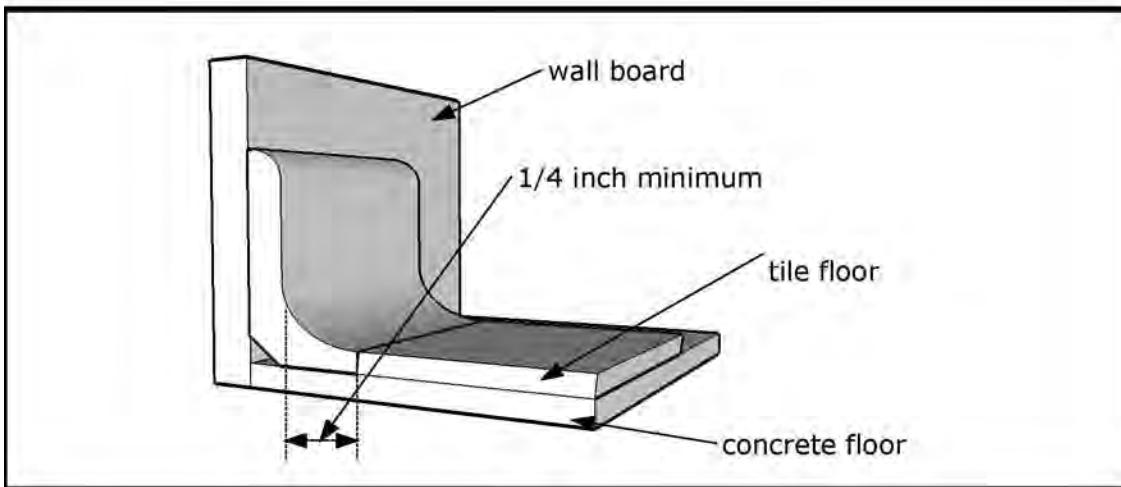

Quarry Tile
Cove base

Installed flush
with the floor

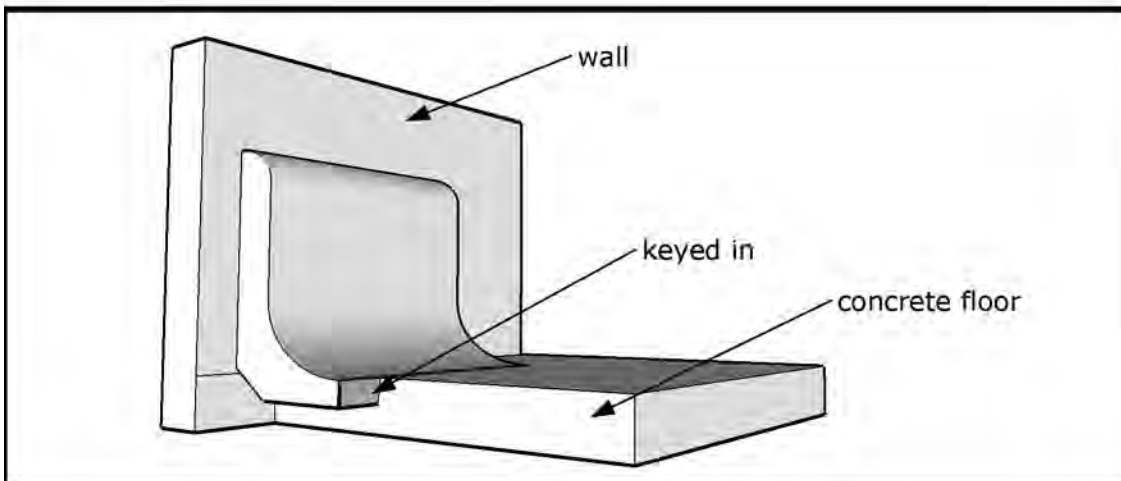

Quarry Tile
Cove base tile

Keyed in integral to
the concrete floor

FLOOR MATERIALS FOR RETAIL FOOD FACILITIES

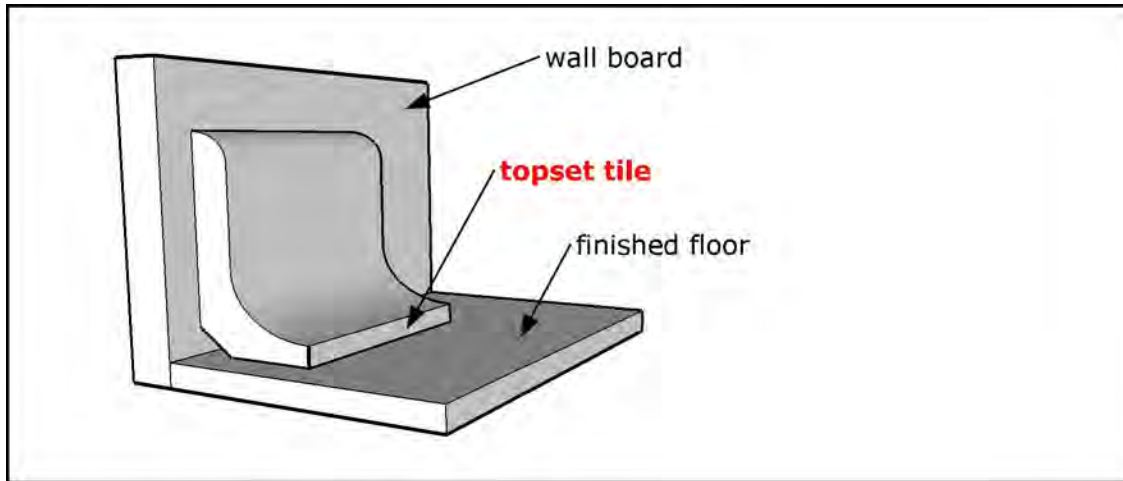

Quarry Tile

Cove base

Incorrect topset installation

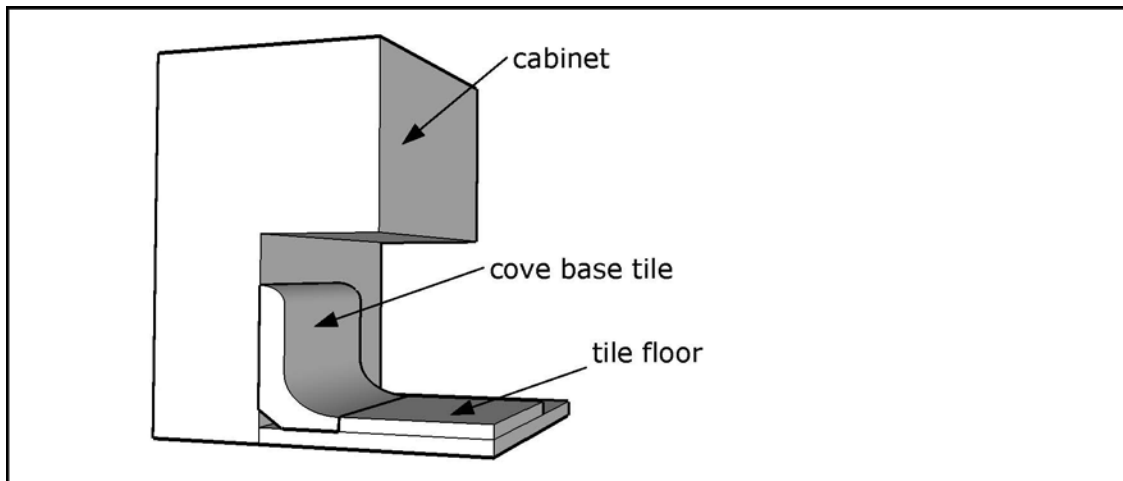

Cove Base

Cabinet toe-kick

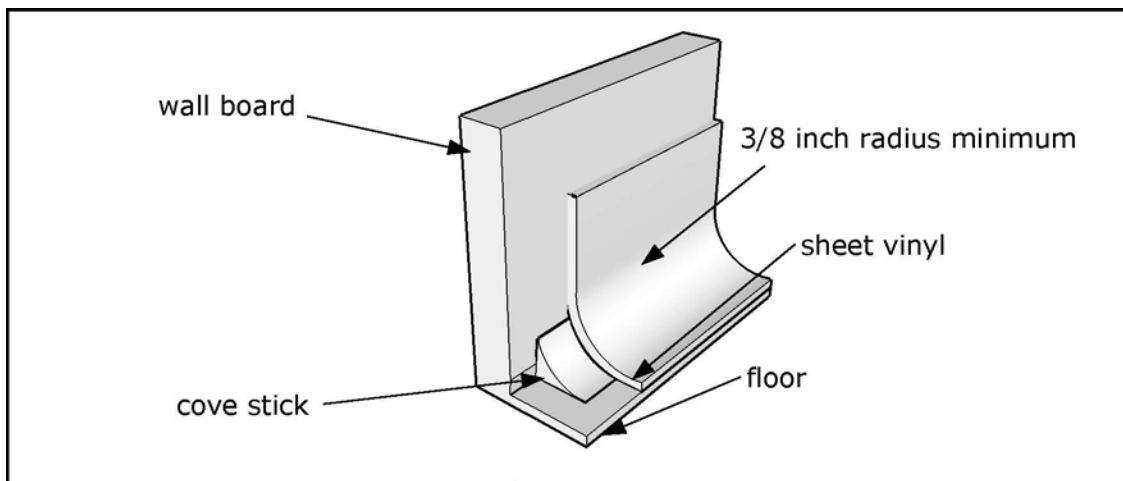

Sheet Vinyl Floor

Correct installation